

DATE	REV.	DESCRIPTION	DR	CK	REL

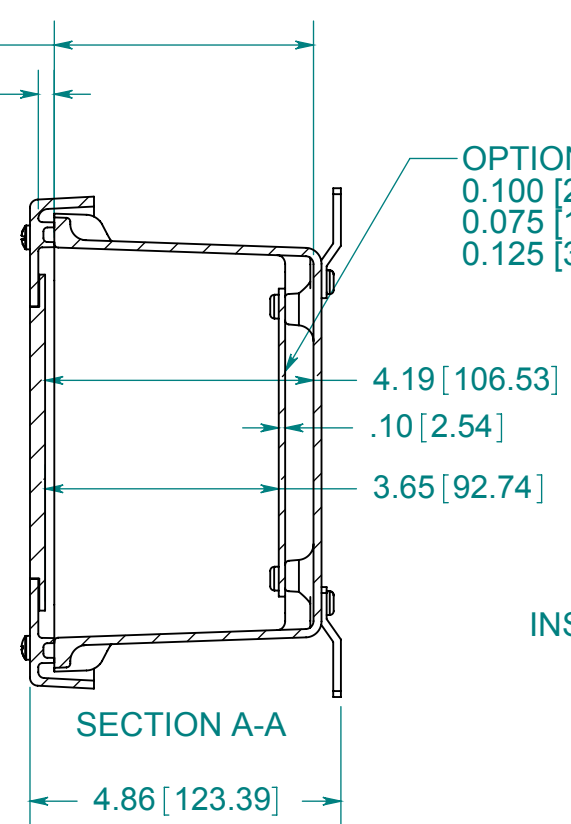

OPTIONAL BACK PANEL
 0.100 [2.54] TH'K- ALUMINUM
 0.075 [1.91] TH'K- WHITE STEEL & GALVANNEALED
 0.125 [3.18] TH'K- FIBERGLASS

(4) STAINLESS STEEL MOUNTING FEET
 (4) EACH #10-32 BRASS INSERTS, AND STAINLESS STEEL FEET SCREWS

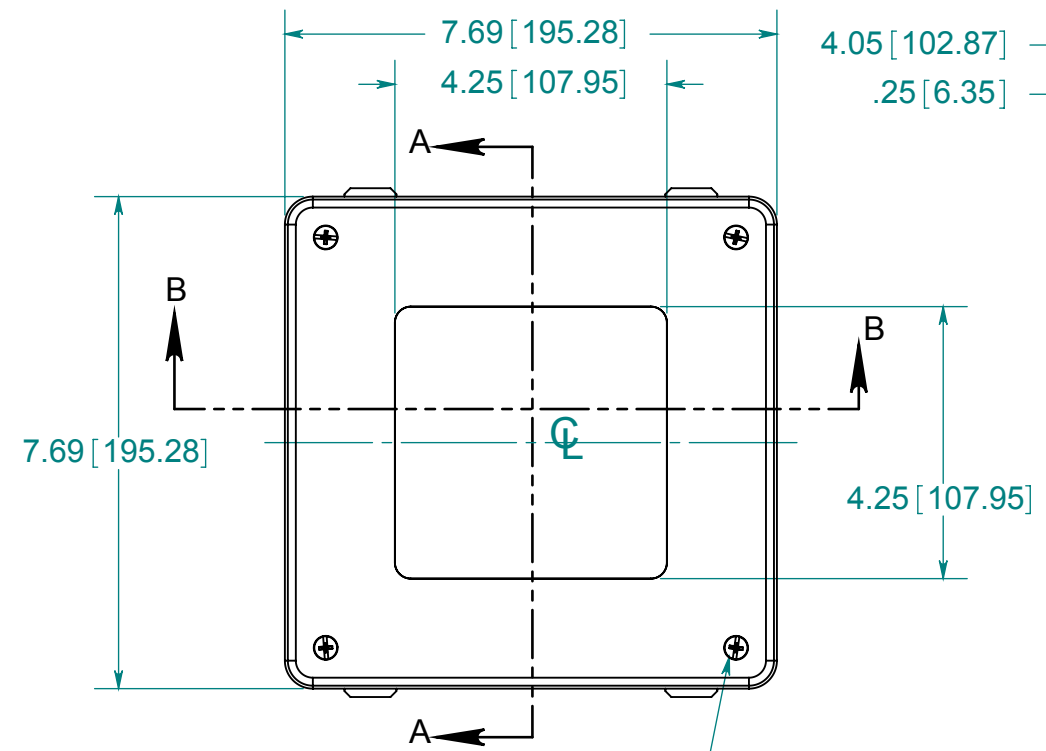
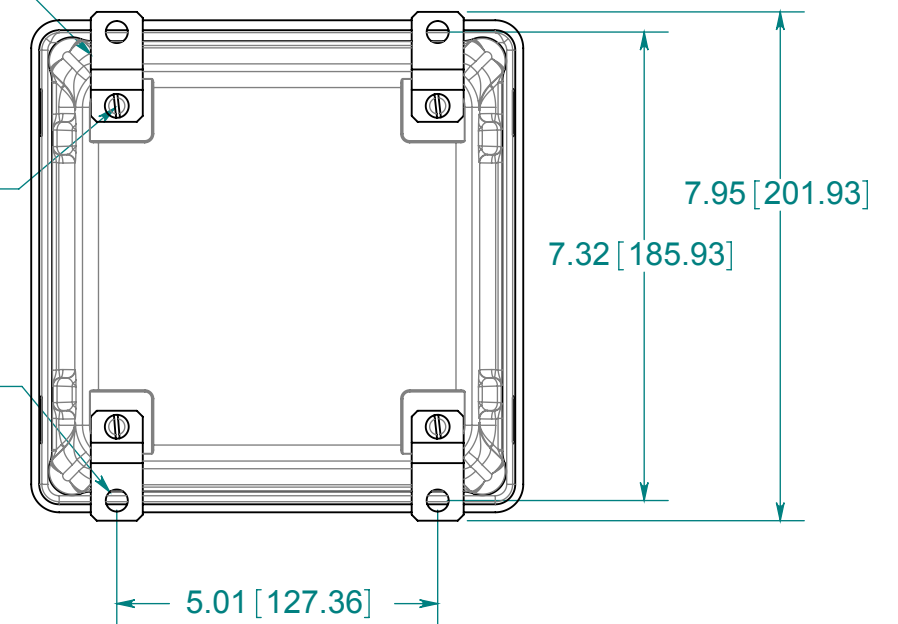

(4) EACH #10-32 BRASS INSERTS AND STAINLESS STEEL CAPTIVE COVER SCREWS WITH RETAINING O-RING

CLOSED CELL NEOPRENE GASKET

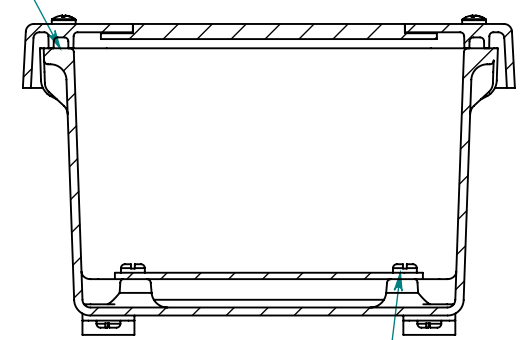

(4) EACH #10-32 BRASS INSERTS AND PLATED CARBON STEEL SCREWS

FRONT VIEW WITH COVER REMOVED AND BACK PANEL SHOWN

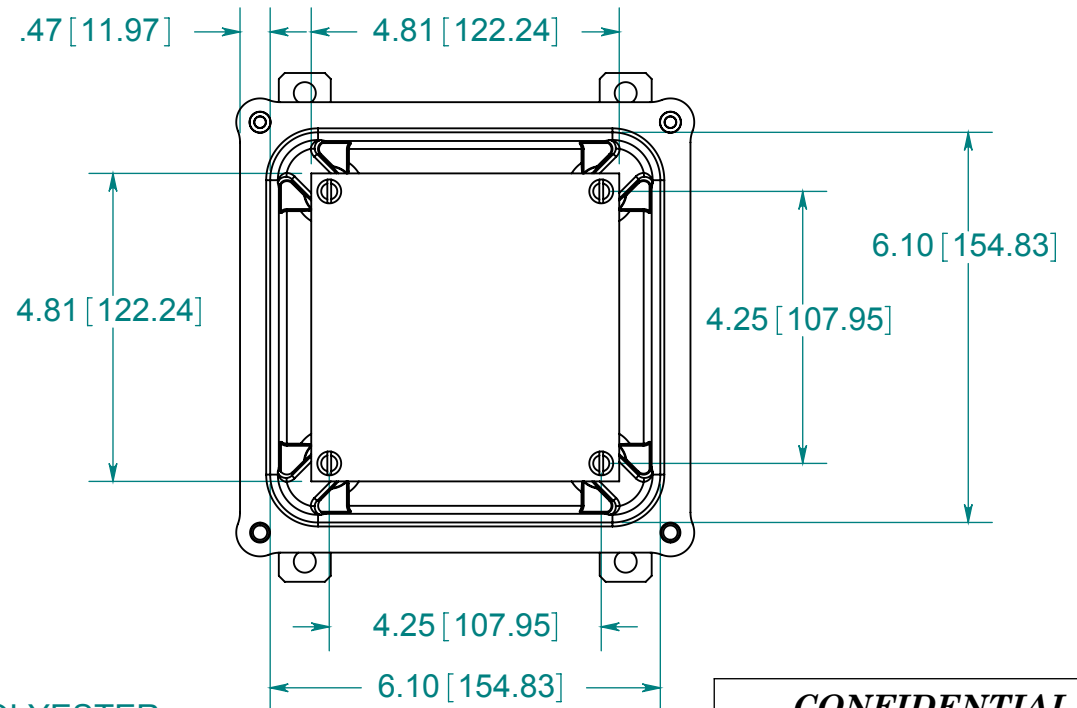

MATERIAL:
 BOX- COMPRESSION MOLDED FIBERGLASS REINFORCED POLYESTER
 COVER- COMPRESSION MOLDED FIBERGLASS REINFORCED POLYESTER
 WINDOW- POLYCARBONATE

CONFIDENTIAL
 THIS MATERIAL IS OWNED BY THE ALLIED MOULDED PRODUCTS COMPANY, IS DISCLOSED IN CONFIDENCE, AND IS NOT TO BE REPRODUCED OR DISTRIBUTED WITHOUT PRIOR WRITTEN PERMISSION FROM ALLIED MOULDED PRODUCTS.

 **ALLIED MOULDED PRODUCTS**
 BRYAN, OHIO
 The Original Fiber Glass Outlet Box

PRODUCT SERIES
AM JIC
 PART No.
AM664W