

# AMU1206CCL

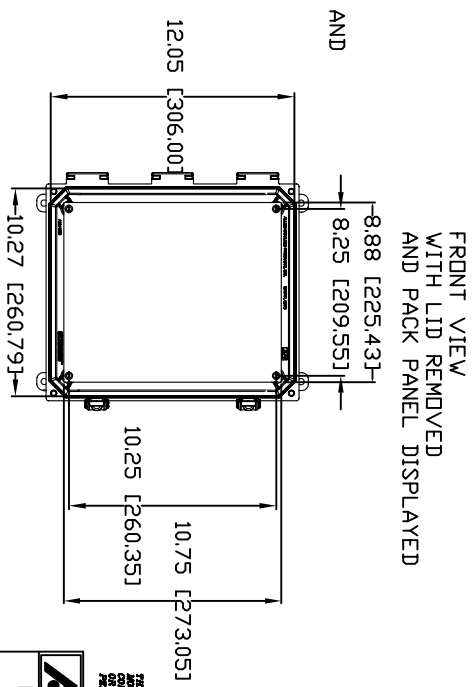
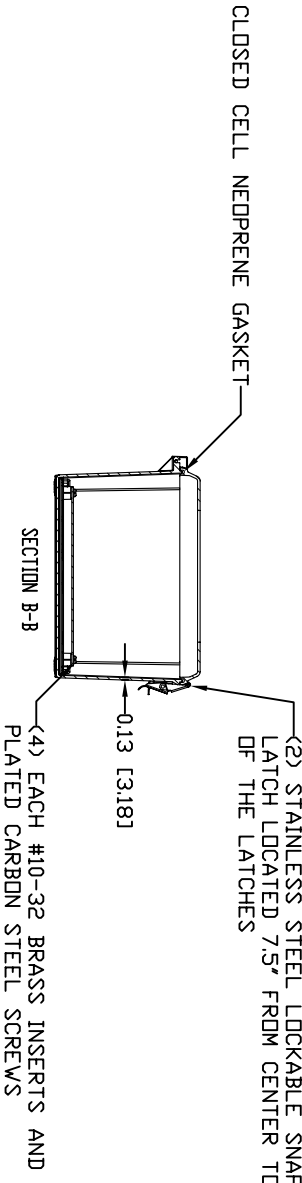
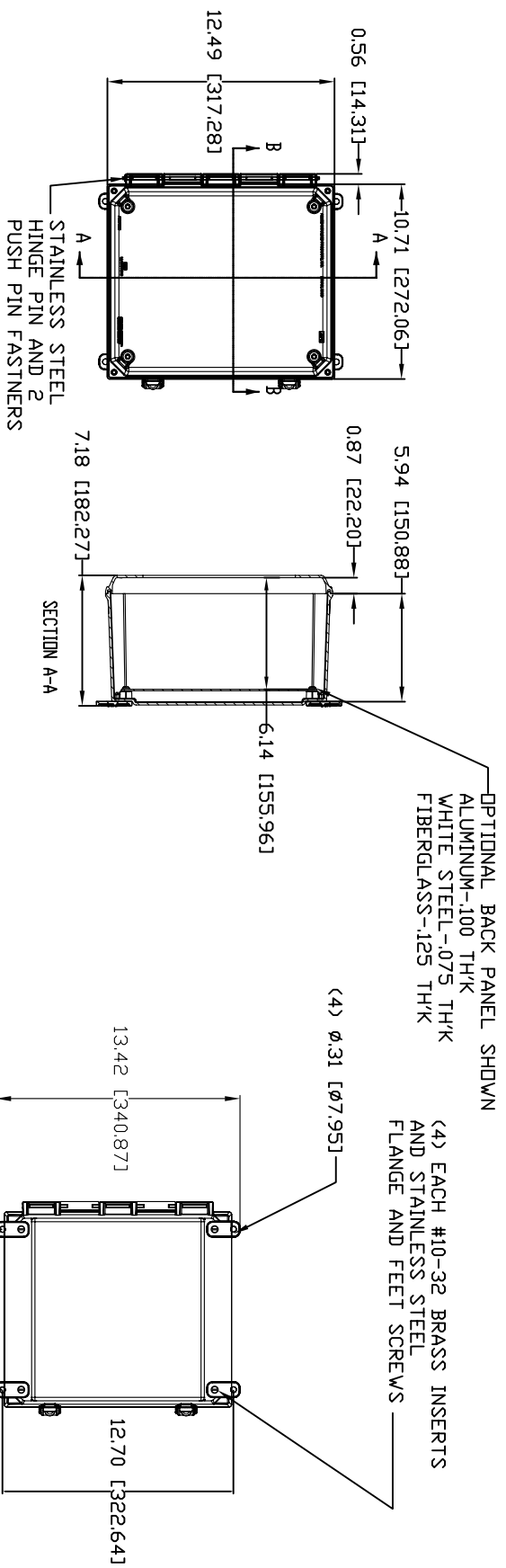

MATERIAL:  
 BOX-COMPRESSION MOLDED FIBERGLASS REINFORCED POLYESTER  
 COVER-COMPRESSION MOLDED FIBERGLASS REINFORCED POLYESTER  
 CLEAR COVER AND WINDOWS-POLYCARBONATE

CONFIDENTIAL

THIS MATERIAL IS OWNED BY THE ALLED GROUP AND IS NOT TO BE REPRODUCED OR DISTRIBUTED WITHOUT WRITTEN PERMISSION FROM ALLED GROUP PRODUCTS.

ALLED GROUP, INC.  
 2000 W. 10th St., Des Moines, IA 50319

ALLED MOLDED PRODUCTS  
 PRODUCT SERIES  
**ULTRALINE™**

REV. 3/22/07