

AMU1206CCT

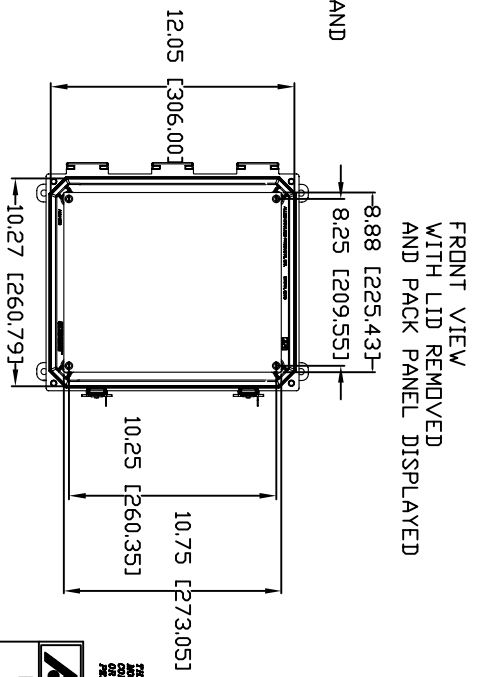
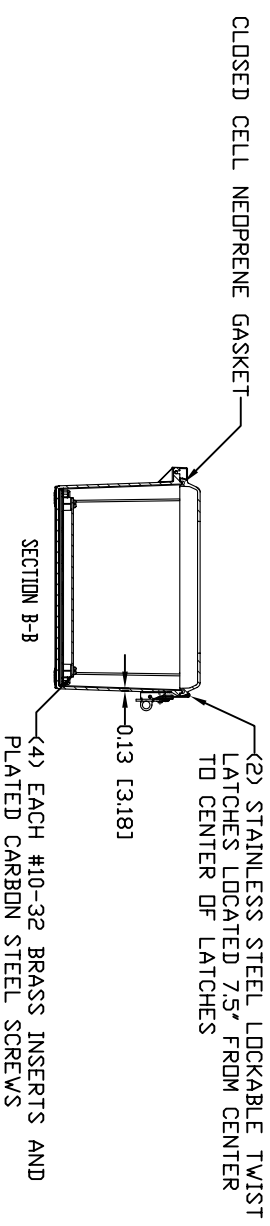
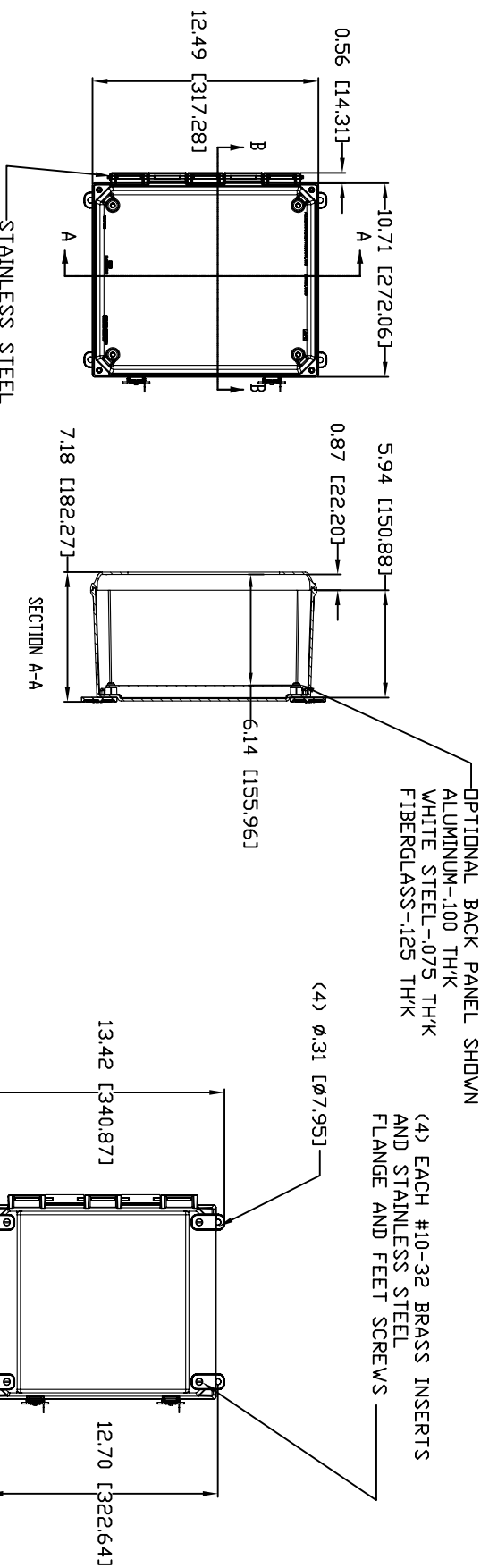

MATERIAL:
 BOX-COMPRESSION MOLDED FIBERGLASS REINFORCED POLYESTER
 COVER-COMPRESSION MOLDED FIBERGLASS REINFORCED POLYESTER
 CLEAR COVER AND WINDOWS-POLYCARBONATE

REV. 3/22/07

CONFIDENTIAL

THIS MATERIAL IS OWNED BY THE ALLED GROUP AND IS NOT TO BE REPRODUCED OR DISTRIBUTED WITHOUT WRITTEN PERMISSION FROM ALLED GROUP PRODUCTS.

ALLED MOLDED PRODUCTS
 The Original Style. The Old Way.

PRODUCT SERIES
 ULTRALINE™