

AMU1206CCTF

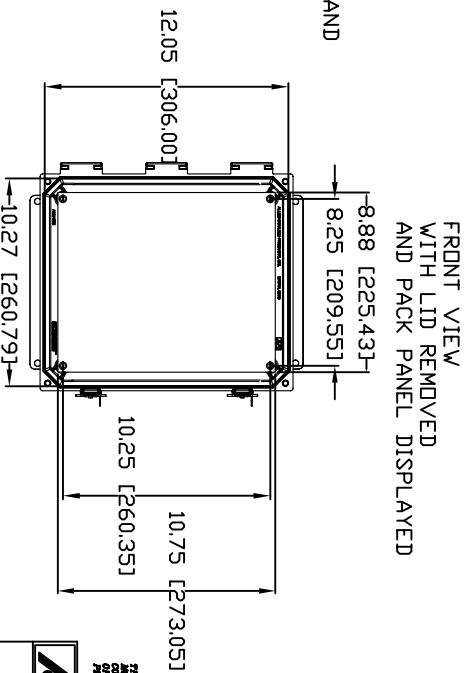
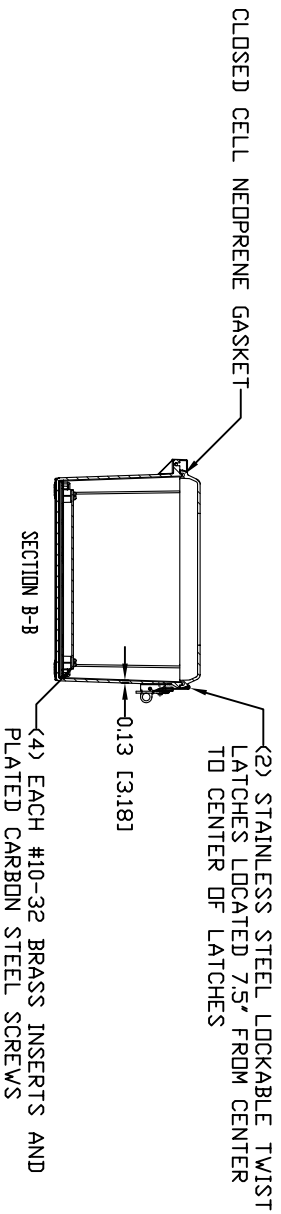
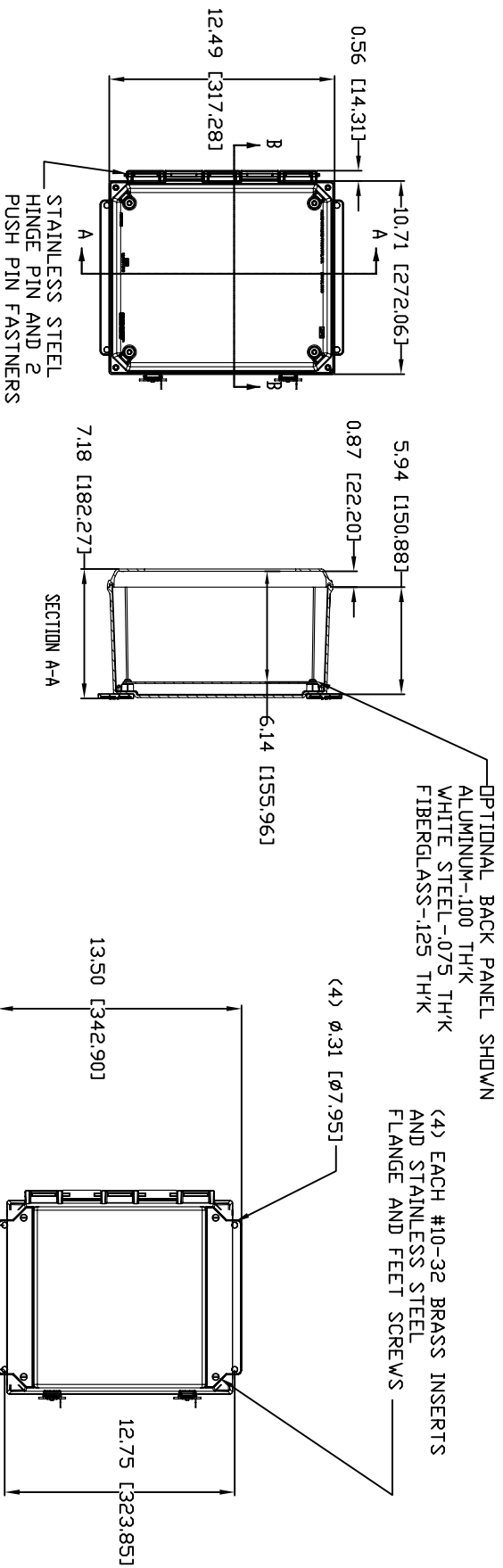

MATERIAL:
 BOX-COMPRESSION MOLDED FIBERGLASS REINFORCED POLYESTER
 COVER-COMPRESSION MOLDED FIBERGLASS REINFORCED POLYESTER
 CLEAR COVER AND WINDOWS-POLYCARBONATE

REV. 3/22/07

ULTRALINE™

ALLIED MOLDED PRODUCTS
 2000 W. 12th St., Lima, OH 44803
 419-225-1234

THIS MATERIAL IS OFFERED BY THE ALLIED GROUP OF COMPANIES AS A SERVICE TO OUR CUSTOMERS. IT IS NOT TO BE REPRODUCED OR DISTRIBUTED WITHOUT THE WRITTEN PERMISSION FROM ALLIED MOLDED PRODUCTS.

CONFIDENTIAL