

AMU1206HW

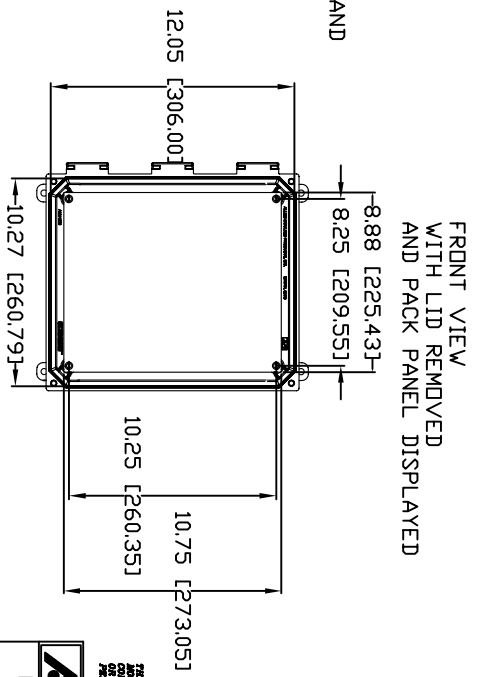
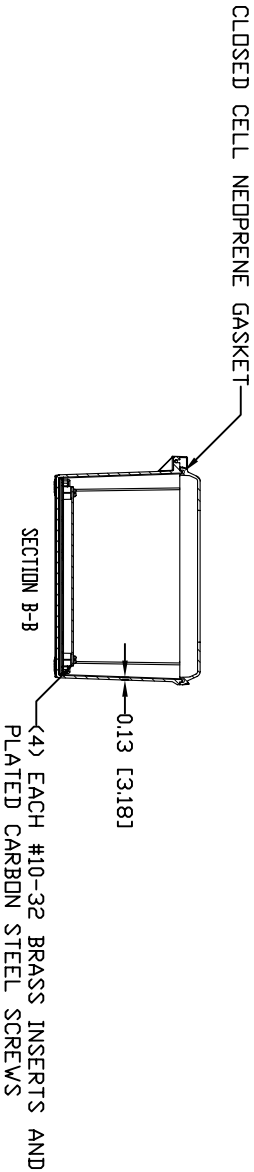
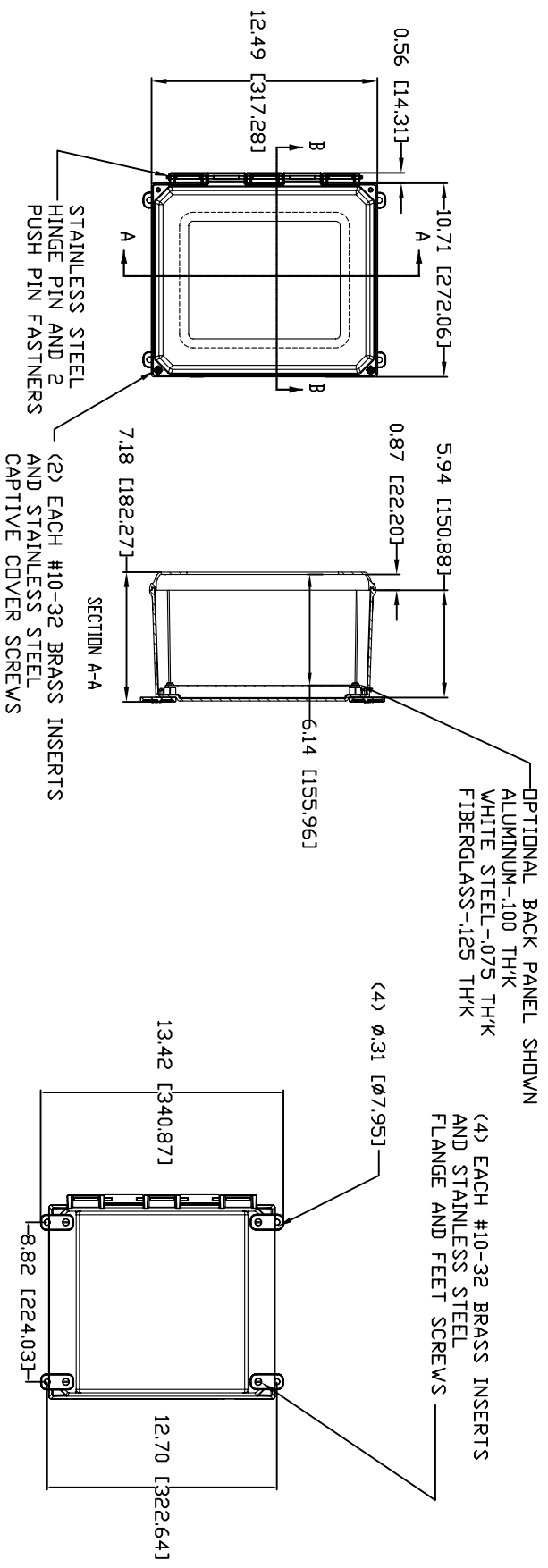

MATERIAL:
 BOX-COMPRESSION MOLDED FIBERGLASS REINFORCED POLYESTER
 COVER-COMPRESSION MOLDED FIBERGLASS REINFORCED POLYESTER
 CLEAR COVER AND WINDOWS-POLYCARBONATE

REV. 3/22/07

ULTRALINE™

ALLIED MOLDED PRODUCTS
 2000 W. 10th St., Lima, OH 44803
 (419) 225-4331

THIS MATERIAL IS OFFERED BY THE ALLIED GROUP AS A SERVICE TO OUR CUSTOMERS. IT IS NOT TO BE REPRODUCED OR DISTRIBUTED WITHOUT THE WRITTEN PERMISSION OF THE ALLIED GROUP. THE ALLIED GROUP ASSUMES NO LIABILITY FOR ANY DAMAGE OR LOSS OF PROFITS RESULTING FROM THE USE OF THIS MATERIAL.