

AMU1206HWF

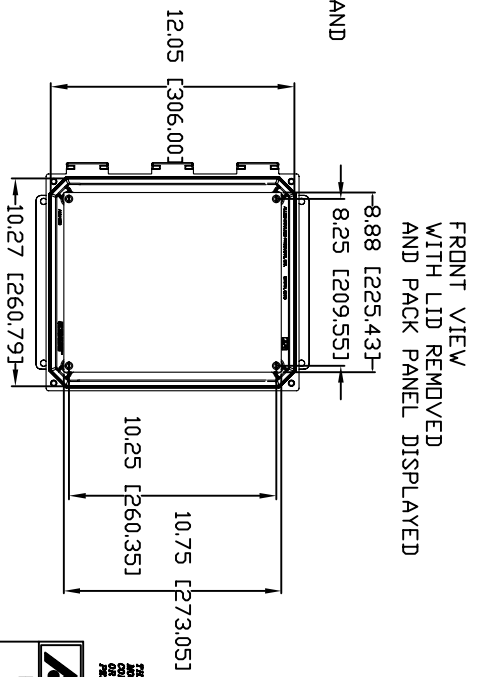
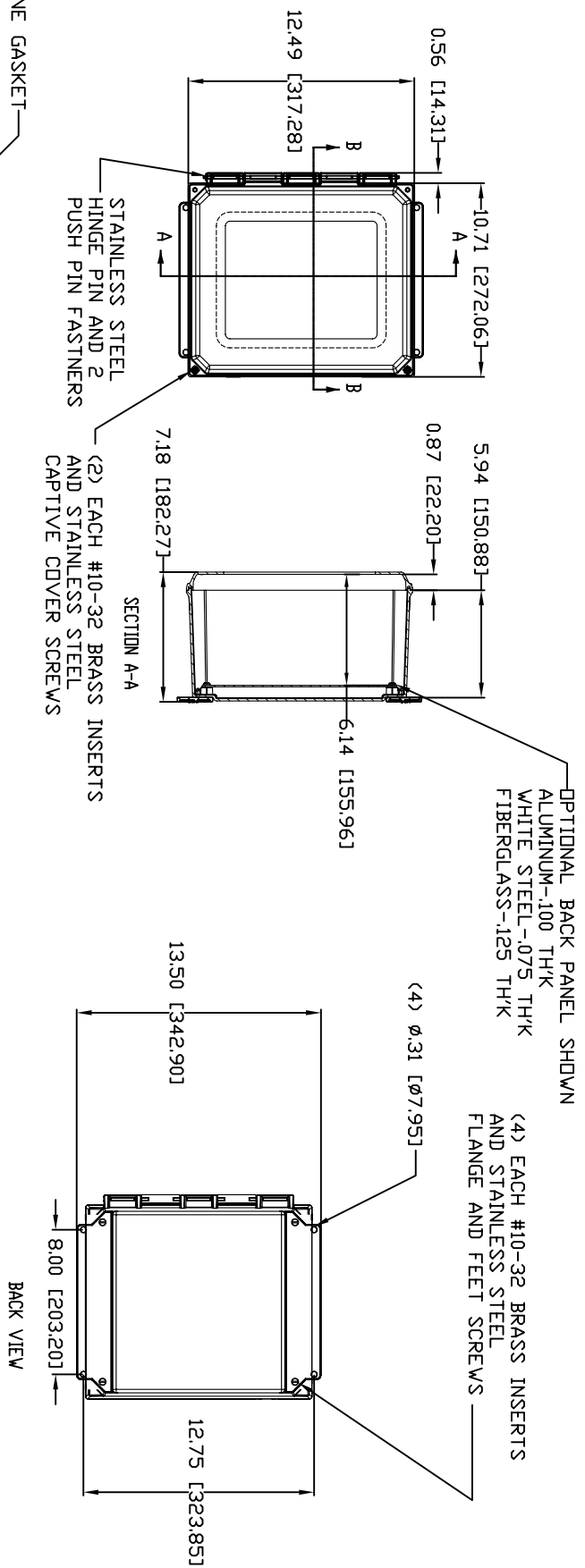

MATERIAL:
 BOX-COMPRESSION MOLDED FIBERGLASS REINFORCED POLYESTER
 COVER-COMPRESSION MOLDED FIBERGLASS REINFORCED POLYESTER
 CLEAR COVER AND WINDOWS-POLYCARBONATE

CONFIDENTIAL
 THIS MATERIAL IS INTENDED FOR THE ALIAD PRODUCT SERIES AND IS NOT TO BE REPRODUCED OR DISTRIBUTED WITHOUT WRITTEN PERMISSION FROM ALIAD MOULDED PRODUCTS.

ALIAD MOULDED PRODUCTS
 The Original. Still. Here. Over Time.
 PRODUCT SERIES
ULTRALINE™

REV. 3/22/07