

AMU1206LW

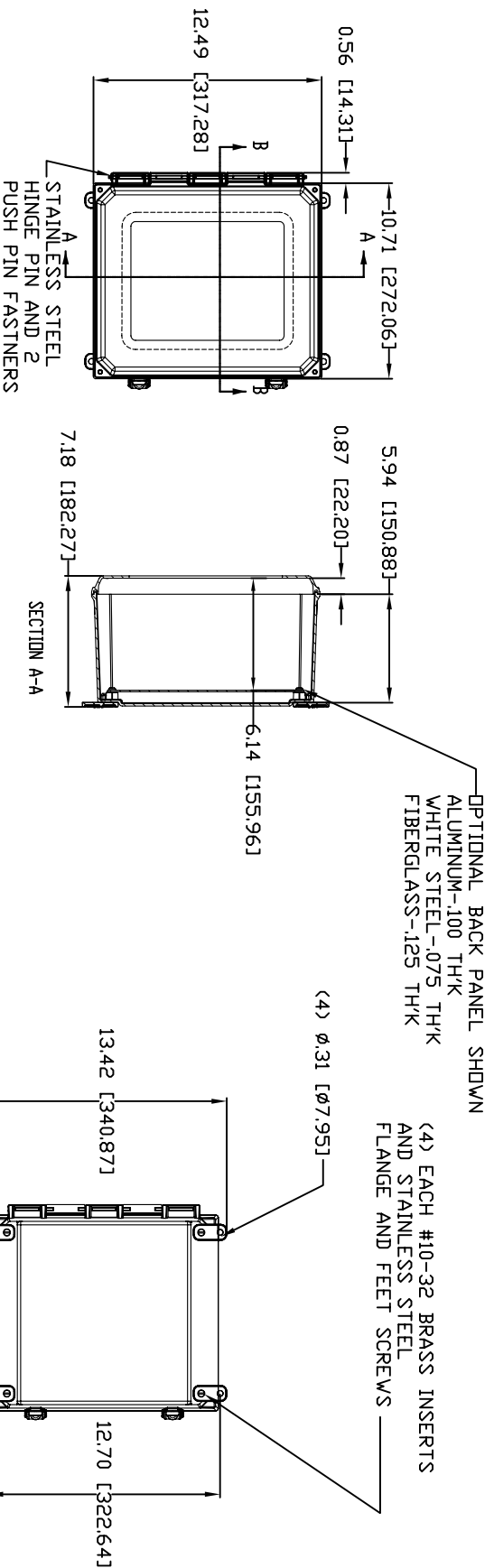

CLOSED CELL NEOPRENE GASKET

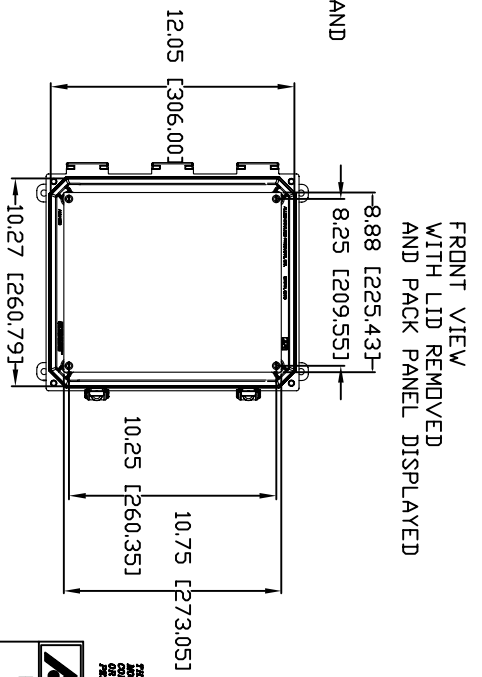
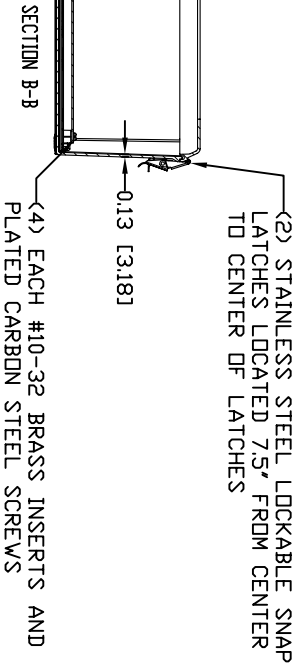

MATERIAL:
 BOX-COMPRESSION MOLDED FIBERGLASS REINFORCED POLYESTER
 COVER-COMPRESSION MOLDED FIBERGLASS REINFORCED POLYESTER
 CLEAR COVER AND WINDOWS-POLYCARBONATE

REV. 3/22/07

CONFIDENTIAL

THIS MATERIAL IS OFFERED BY THE ALLIED GROUP AS A SERVICE TO OUR CUSTOMERS. IT IS NOT TO BE REPRODUCED OR DISTRIBUTED WITHOUT THE WRITTEN PERMISSION FROM ALLIED GROUP PRODUCTS.

ALLIED MOLDED PRODUCTS
 The Original Style. The Old Way.

PRODUCT SERIES
 ULTRALINE™