

AMU1206LWF

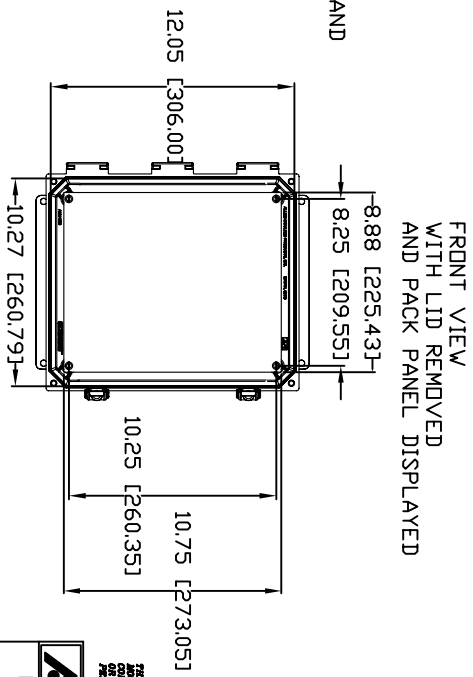
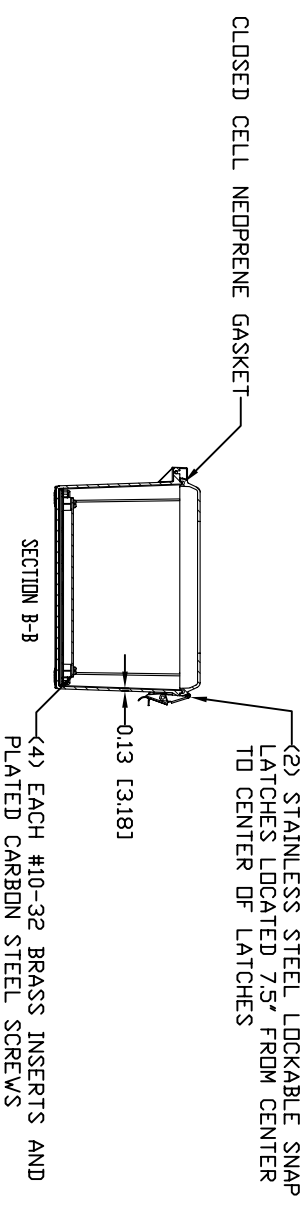
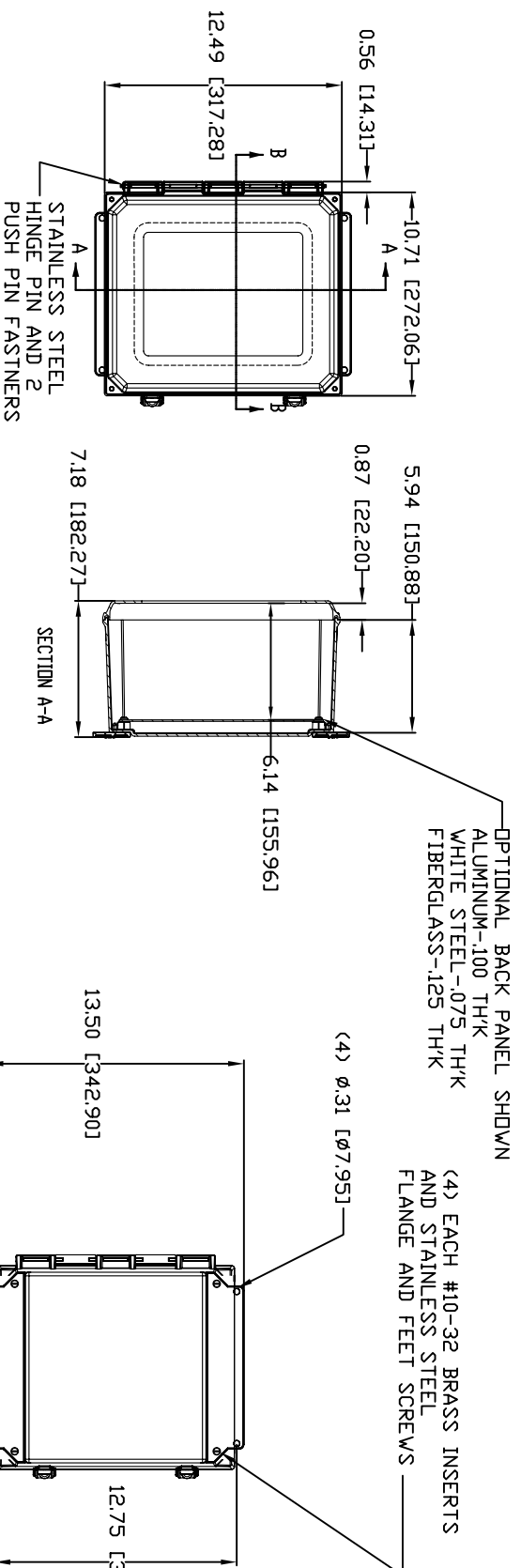

MATERIAL:
BOX-COMPRESSION MOLDED FIBERGLASS REINFORCED POLYESTER
COVER-COMPRESSION MOLDED FIBERGLASS REINFORCED POLYESTER
CLEAR COVER AND WINDOWS-POLYCARBONATE

CONFIDENTIAL

THIS MATERIAL IS OWNED BY THE ALLIED
CORPORATION AND IS NOT TO BE REPRODUCED
OR DISTRIBUTED WITHOUT PRIOR WRITTEN
PERMISSION FROM THE SALES AND SERVICE DEPARTMENT.

ALLIED MOLDED PRODUCTS
The Original Since 1946

PRODUCT SERIES
ULTRALINE™

REV. 3/22/07