

AMU1426TWF

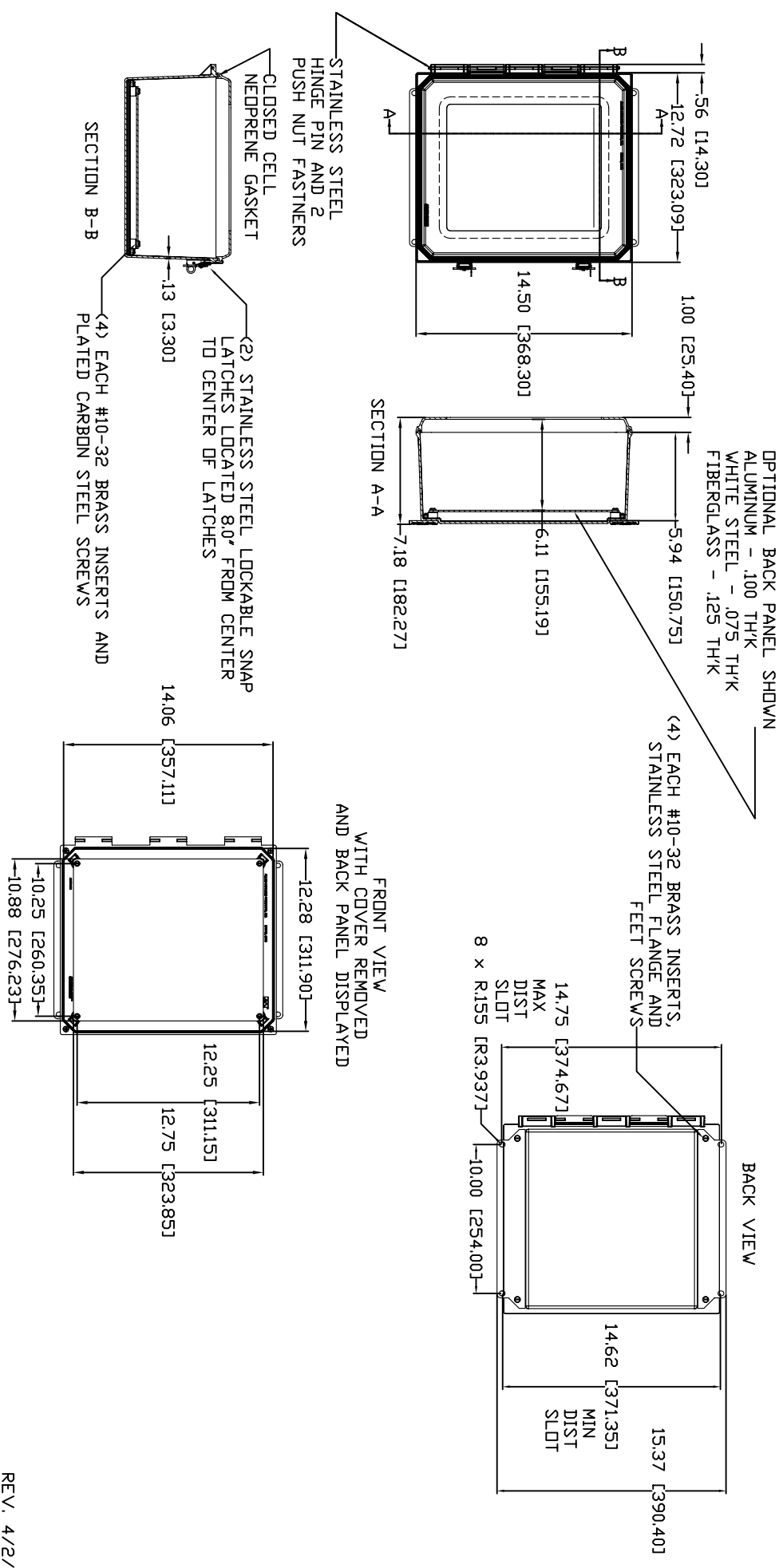

MATERIAL:
 BOX-COMPRESSION MOLDED FIBERGLASS REINFORCED POLYESTER
 COVER-COMPRESSION MOLDED FIBERGLASS REINFORCED POLYESTER
 CLEAR COVER AND WINDOWS-POLYCARBONATE

CONFIDENTIAL

THIS MATERIAL IS OWNED BY THE ALLIED ULTRALINE™ SERIES AND IS TO BE REPRODUCED OR TRANSMITTED IN ANY FORM OR BY ANY MEANS WITHOUT THE WRITTEN PERMISSION OF THE MANUFACTURER.

ALLIED MOLDED PRODUCTS
 The Original Molded Case, Clear Case

PRODUCT SERIES
 ULTRALINE™

REV. 4/2/07