

AMU1860L WF

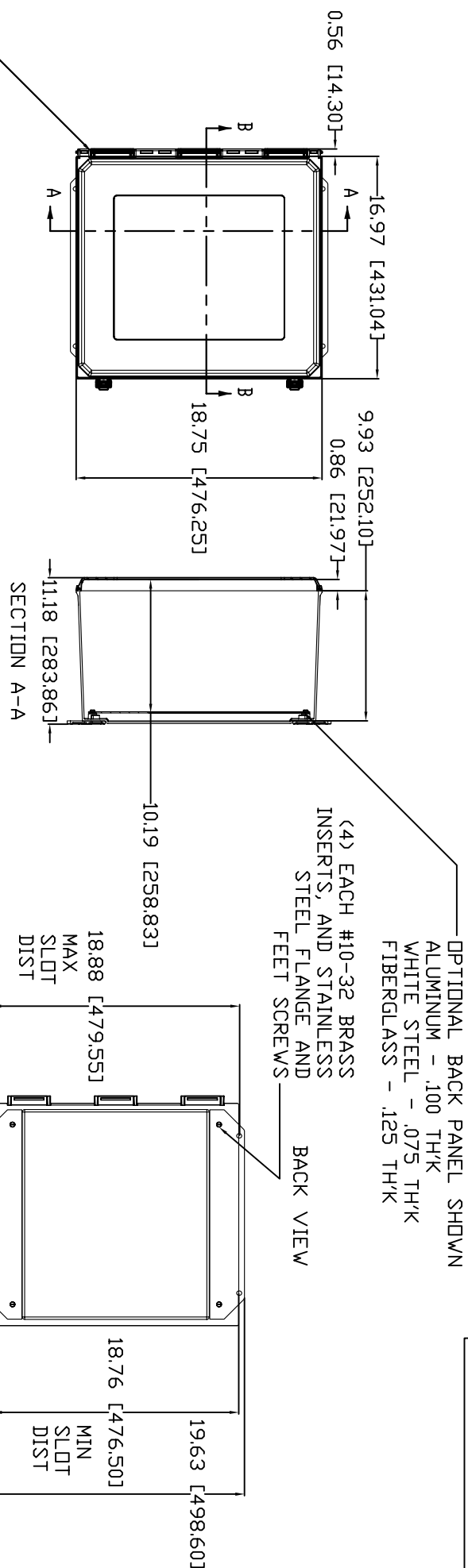

STAINLESS STEEL HINGE PIN AND 2 PUSH NUT FASTENERS

CLOSED CELL NEOPRENE GASKET

(2) STAINLESS STEEL LOCKABLE SNAP LATCHES LOCATED 9.5" FROM CENTER TO CENTER OF LATCHES

(4) EACH #10-32 BRASS INSERTS AND PLATED CARBON STEEL SCREWS

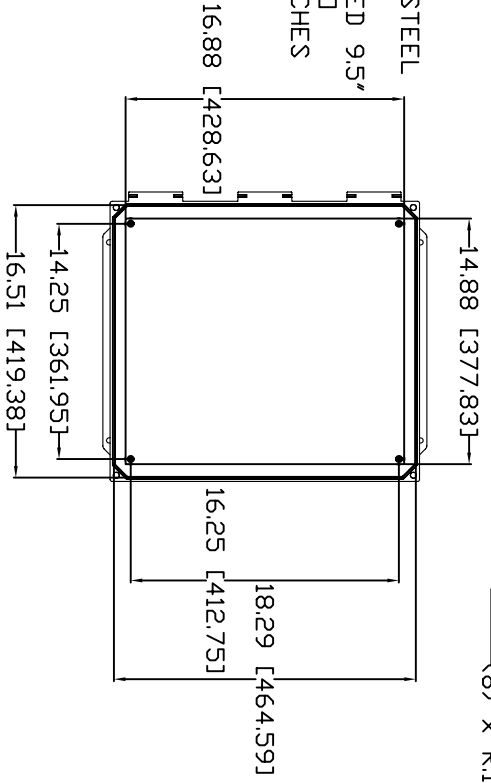

MATERIAL:
 BOX-COMPRESSION MOLDED FIBERGLASS REINFORCED POLYESTER COVER-COMPRESSION MOLDED FIBERGLASS REINFORCED POLYESTER CLEAR COVER AND WINDOWS-POLYCARBONATE

REV. 12/12/07
 REV. 4/2/07

