

AMU864

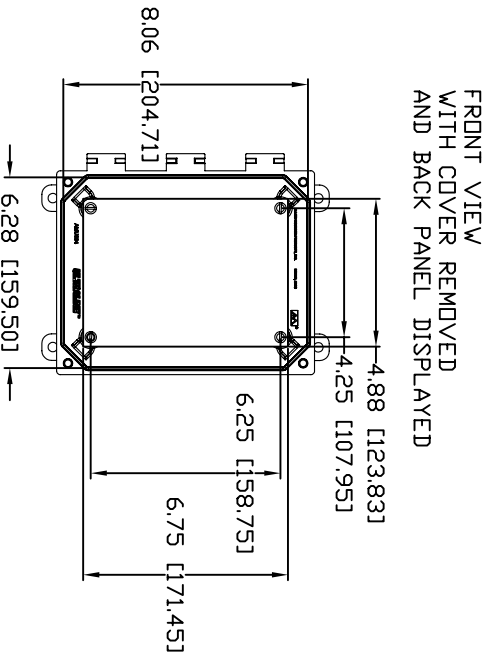
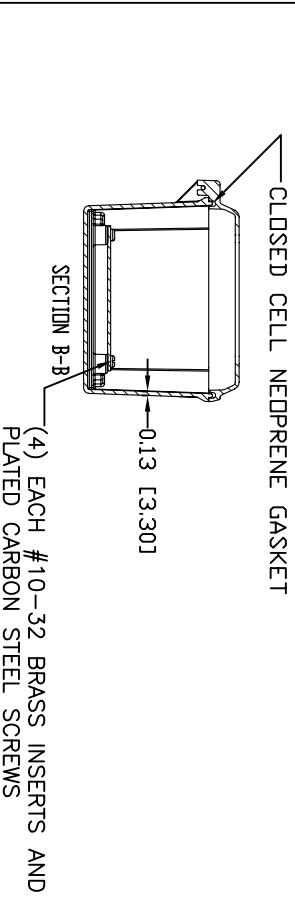
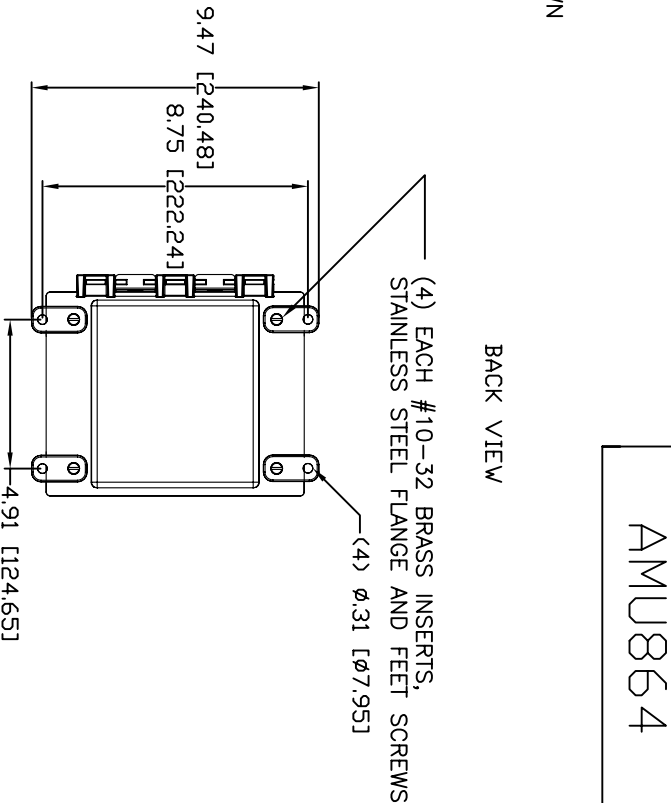
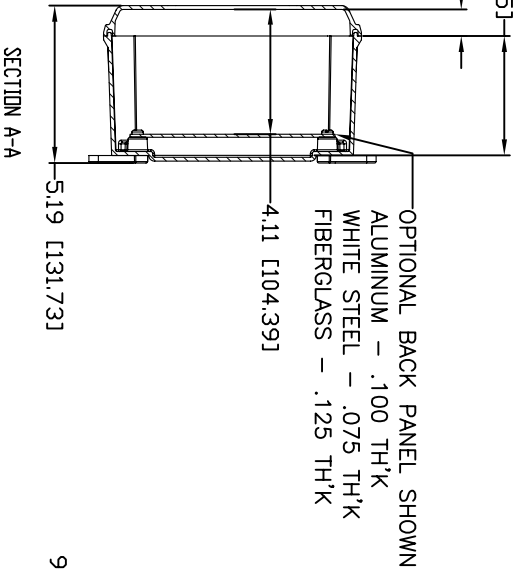
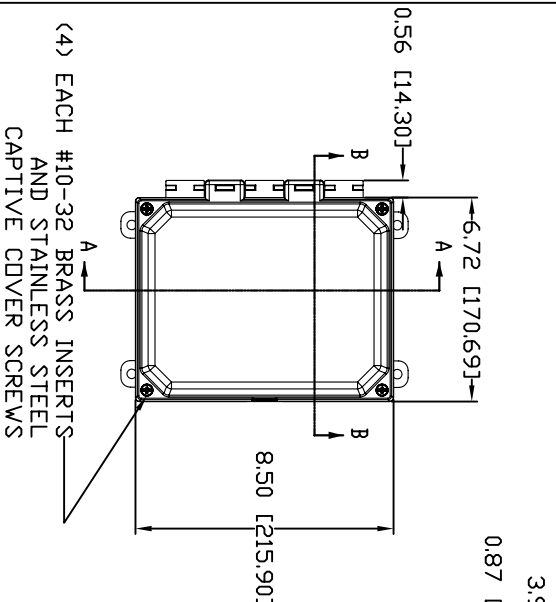

MATERIAL:
 BOX-COMPRESSION MOLDED FIBERGLASS REINFORCED POLYESTER
 COVER-COMPRESSION MOLDED FIBERGLASS AND REINFORCED POLYESTER
 CLEAR COVER AND WINDOWS-POLYCARBONATE

REV. 3/19/07

CONFIDENTIAL
 THE ABOVE INFORMATION IS UNCLASSIFIED
 EXCEPT WHERE SHOWN OTHERWISE IN
 THIS DOCUMENT AND IS NOT TO BE
 REPRODUCED OR TRANSMITTED IN ANY
 FORM OR BY ANY MEANS, ELECTRONIC
 OR MECHANICAL, INCLUDING
 PHOTOCOPYING, RECORDING, OR BY
 INFORMATION STORAGE AND RETRIEVAL
 SYSTEMS, WITHOUT PERMISSION FROM
 ALLIED MOLDED PRODUCTS

ALLIED MOLDED PRODUCTS
 20000 W. 17th Ave., Suite 100, Greeley, CO 80639

PRODUCT SERIES
 ULTRALINE™