

AMU864CCT

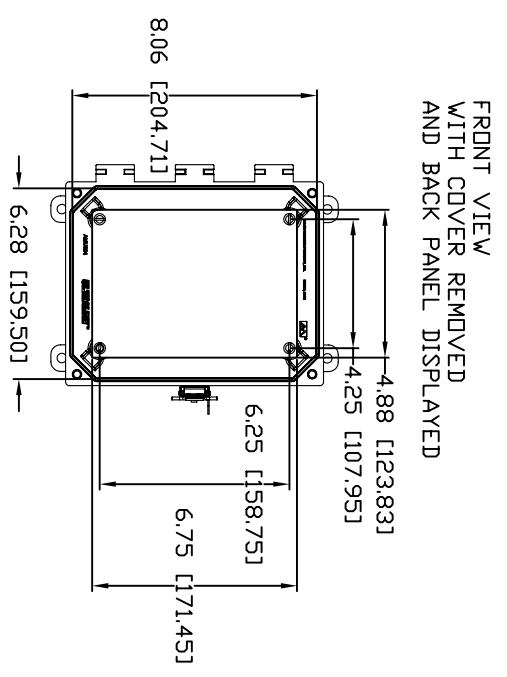
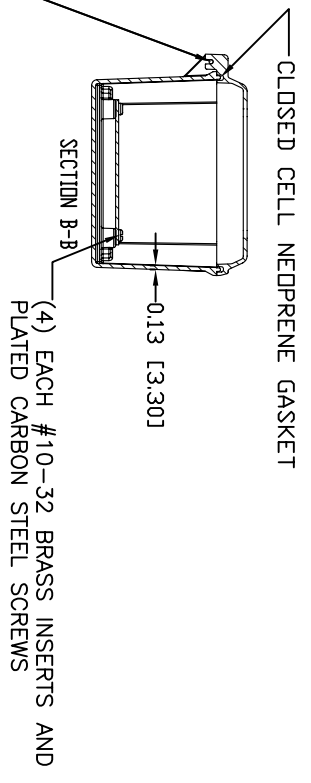
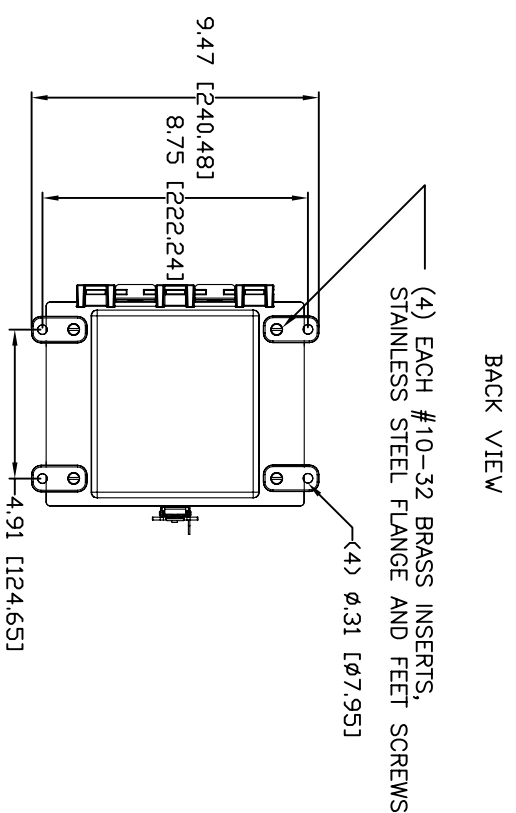
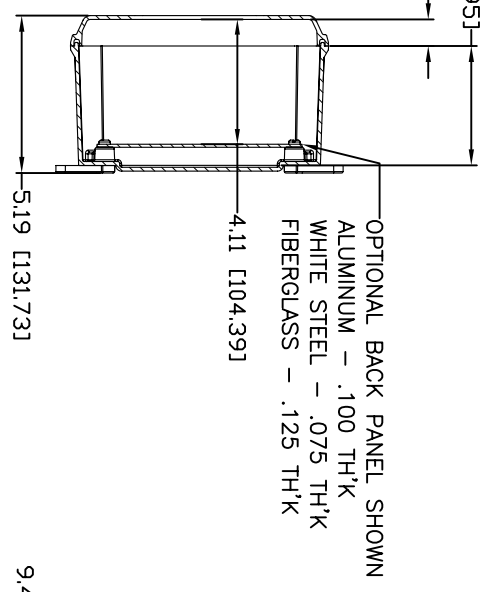
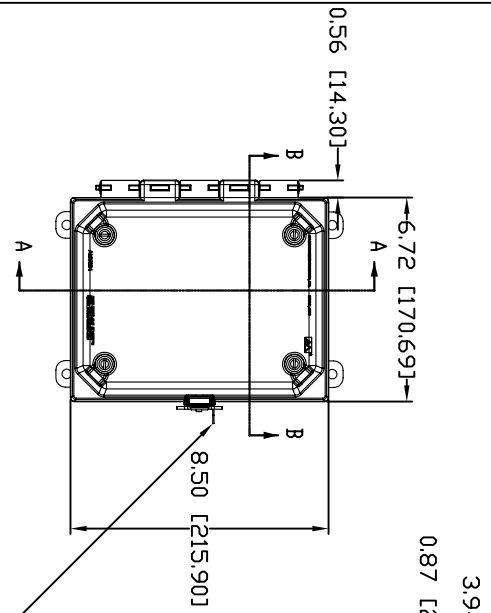

MATERIAL:
 BOX-COMPRESSION MOLDED FIBERGLASS REINFORCED POLYESTER
 COVER-COMPRESSION MOLDED FIBERGLASS AND REINFORCED POLYESTER
 CLEAR COVER AND WINDOWS-POLYCARBONATE

REV. 3/19/07

CONFIDENTIAL

THIS DRAWING IS THE PROPERTY OF ALLIED WOUND PRODUCTS. IT IS TO BE KEPT IN CONFIDENTIALITY AND IS NOT TO BE REPRODUCED OR TRANSMITTED IN ANY FORM OR BY ANY MEANS, ELECTRONIC OR MECHANICAL, INCLUDING PHOTOCOPYING, RECORDING, OR BY ANY INFORMATION STORAGE AND RETRIEVAL SYSTEM, WITHOUT PERMISSION FROM ALLIED WOUND PRODUCTS.

ALLIED WOUND PRODUCTS
 2600 Bryn Mawr Blvd., Dayton, Ohio 45424

PRODUCT SERIES
 ULTRALINE™