

AMU864H

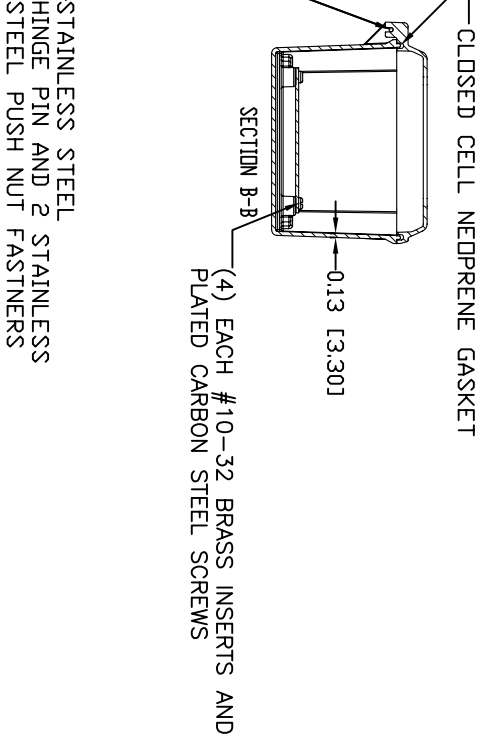
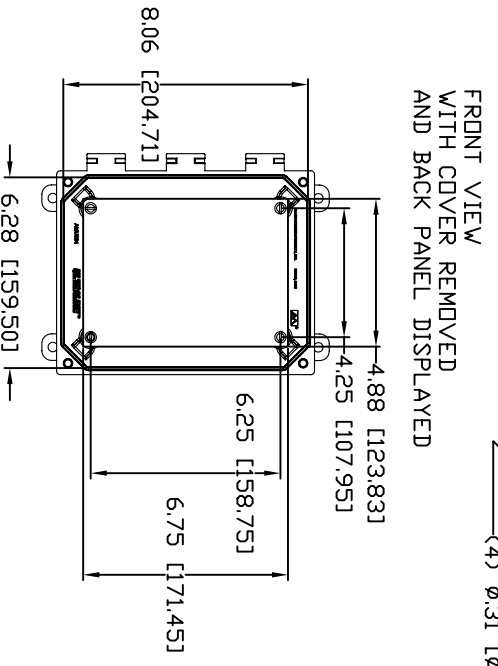
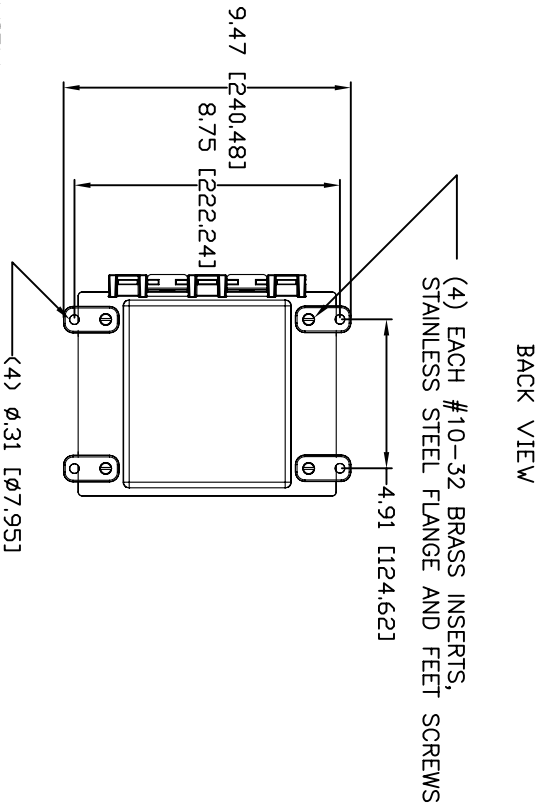
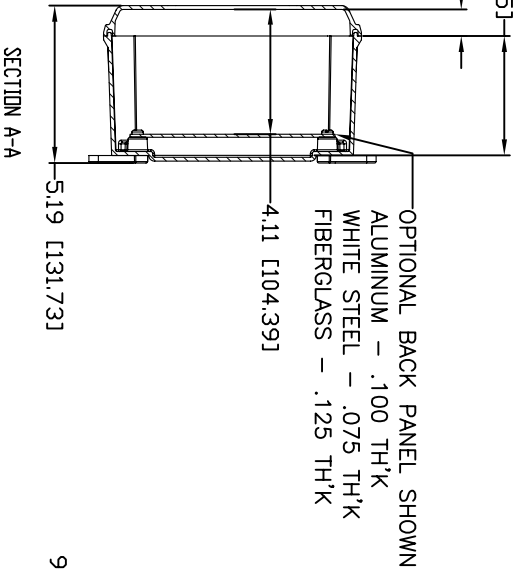
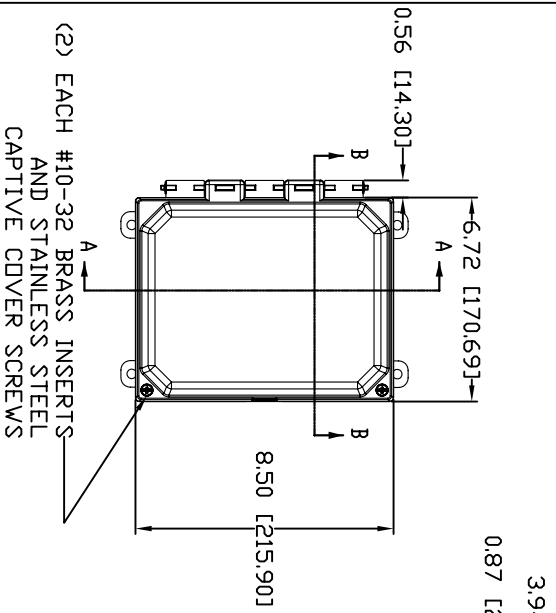

MATERIAL:
 BOX-COMPRESSION MOLDED FIBERGLASS REINFORCED POLYESTER
 COVER-COMPRESSION MOLDED FIBERGLASS AND REINFORCED POLYESTER
 CLEAR COVER AND WINDOWS-POLYCARBONATE

REV. 3/19/07

CONFIDENTIAL

THESE MATERIALS ARE THE PROPERTY OF ALLIED WILCOX AND COMPANY, INC. AND ARE TO BE USED ONLY FOR THE PURPOSES AUTHORIZED BY ALLIED WILCOX AND COMPANY, INC. PERMISSION IS GRANTED TO REPRODUCE THIS DRAWING FOR INFORMATIONAL PURPOSES ONLY.

ALLIED WILCOX PRODUCTS
 10000 BRIVIA, OHIO 44130

PRODUCT SERIES
 ULTRALINE™