

AMU864LW

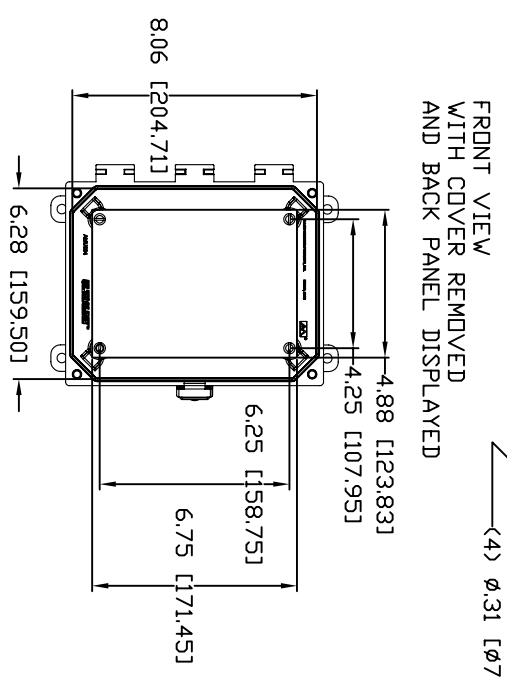
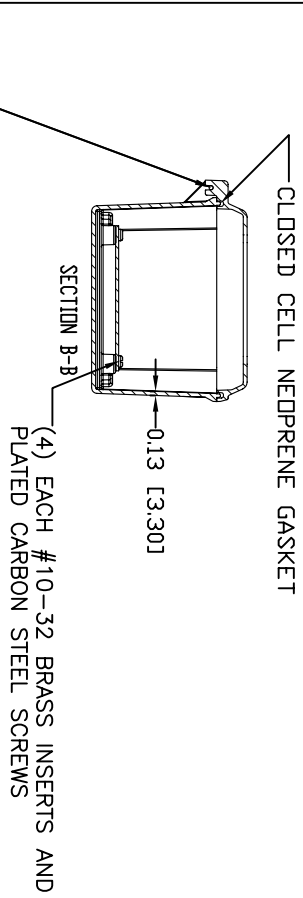
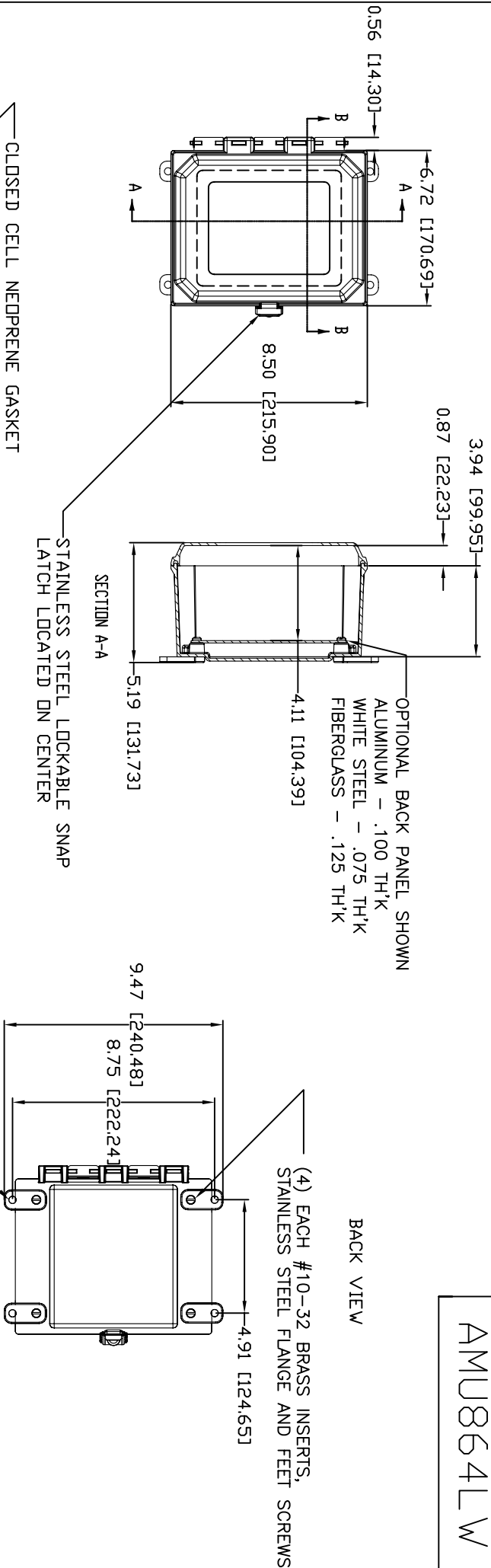

MATERIAL:
 BOX-COMPRESSION MOLDED FIBERGLASS REINFORCED POLYESTER
 COVER-COMPRESSION MOLDED FIBERGLASS AND REINFORCED POLYESTER
 CLEAR COVER AND WINDOWS-POLYCARBONATE

REV. 3/19/07

CONFIDENTIAL

THE NAME, DESIGN, OR OTHER IDENTIFYING INFORMATION CONTAINED HEREIN IS THE PROPERTY OF ALLIED WOUNDED PRODUCTS AND IS TO BE KEPT CONFIDENTIAL AND NOT TO BE REPRODUCED OR TRANSMITTED IN ANY FORM OR BY ANY MEANS, ELECTRONIC OR MECHANICAL, INCLUDING PHOTOCOPYING, RECORDING, OR BY ANY INFORMATION STORAGE AND RETRIEVAL SYSTEM, WITHOUT PERMISSION FROM ALLIED WOUNDED PRODUCTS.

ALLIED WOUNDED PRODUCTS
 10000 BRIVIA, OHIO 44130

PRODUCT SERIES
 ULTRALINE™