

AMU864T

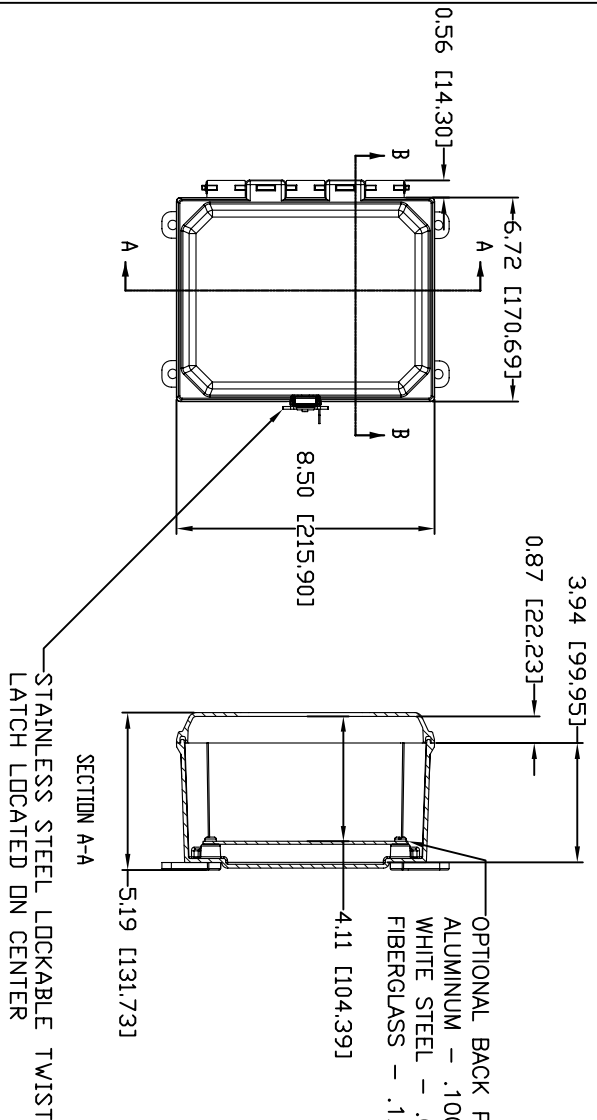

OPTIONAL BACK PANEL SHOWN  
 ALUMINUM - .100 TH'K  
 WHITE STEEL - .075 TH'K  
 FIBERGLASS - .125 TH'K

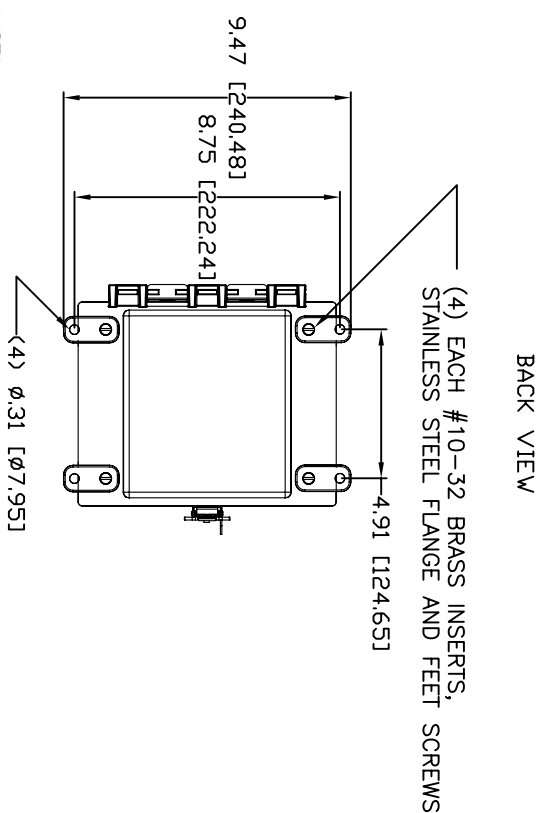

FRONT VIEW  
 WITH COVER REMOVED  
 AND BACK PANEL DISPLAYED

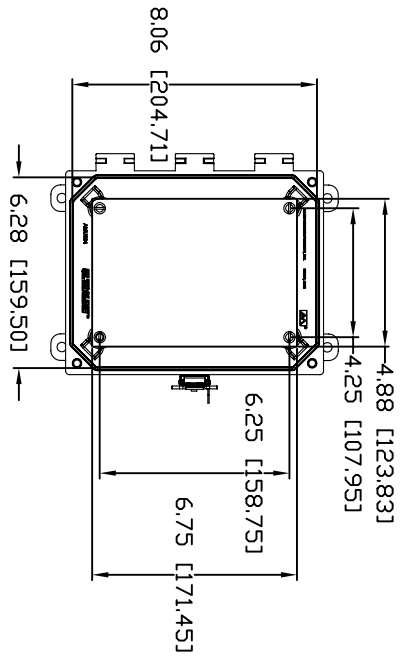

STAINLESS STEEL  
 HINGE PIN AND 2 STAINLESS  
 STEEL PUSH NUT FASTENERS

(4) EACH #10-32 BRASS INSERTS AND  
 PLATED CARBON STEEL SCREWS

MATERIAL:  
 BOX-COMPRESSION MOLDED FIBERGLASS REINFORCED POLYESTER  
 COVER-COMPRESSION MOLDED FIBERGLASS AND REINFORCED POLYESTER  
 CLEAR COVER AND WINDOWS-POLYCARBONATE

REV. 3/19/07

CONFIDENTIAL

THE ABOVE DRAWING IS THE PROPERTY OF ALLIED WILCOX PRODUCTS COMPANY. IT IS TO BE KEPT IN CONFIDENTIALITY AND NOT TO BE REPRODUCED OR TRANSMITTED IN ANY FORM OR BY ANY MEANS, ELECTRONIC OR MECHANICAL, INCLUDING PHOTOCOPYING, RECORDING, OR BY ANY INFORMATION STORAGE AND RETRIEVAL SYSTEM, WITHOUT THE WRITTEN PERMISSION FROM ALLIED WILCOX PRODUCTS COMPANY.

ALLIED WILCOX PRODUCTS  
 10000 WILCOX DRIVE, BRIVIA, OHIO 44138

PRODUCT SERIES  
 ULTRALINE™