

AMU864W

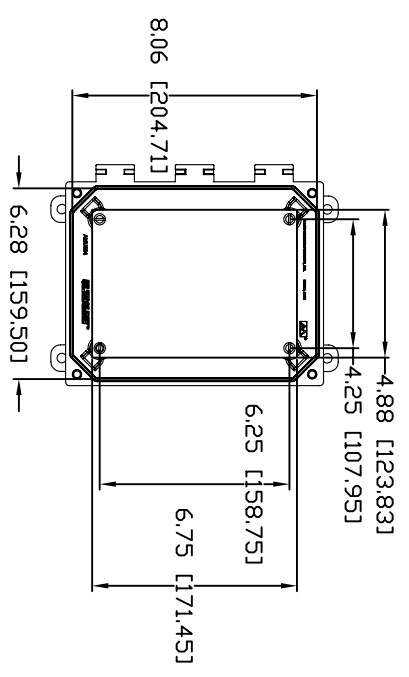
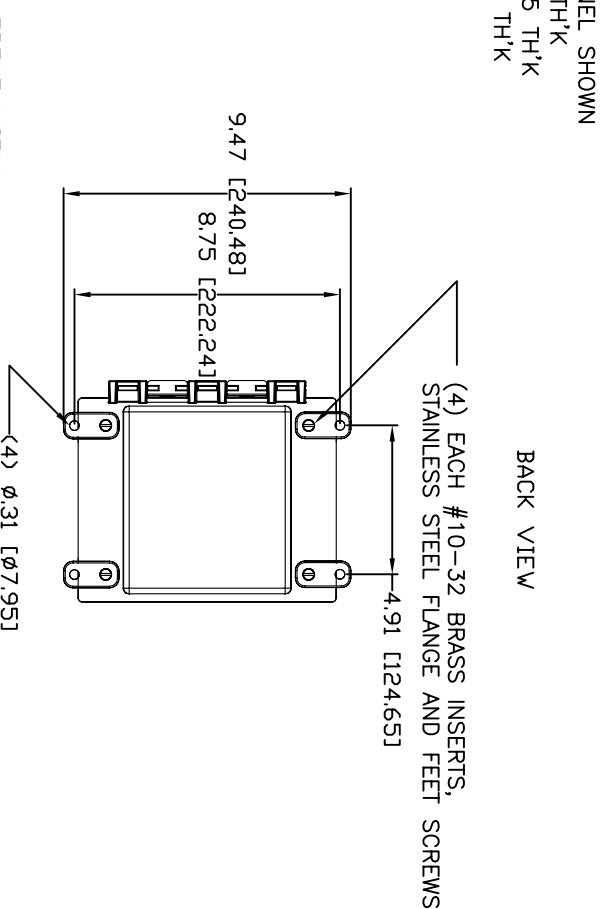
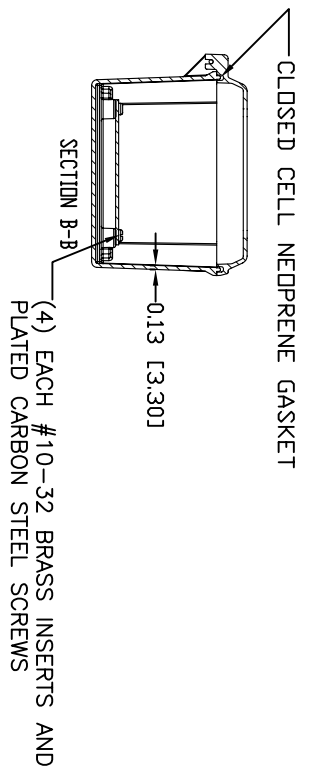
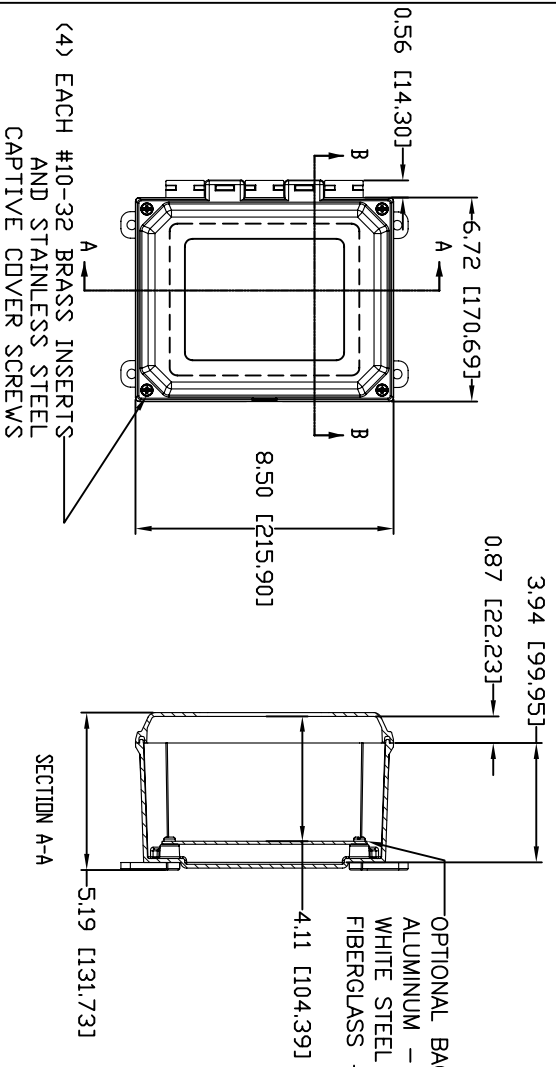

MATERIAL:
 BOX-COMPRESSION MOLDED FIBERGLASS REINFORCED POLYESTER
 COVER-COMPRESSION MOLDED FIBERGLASS AND REINFORCED POLYESTER
 CLEAR COVER AND WINDOWS-POLYCARBONATE

REV. 3/19/07

CONFIDENTIAL

THESE MATERIALS, PRODUCTS, AND METHODS ARE THE PROPERTY OF ALLIED WILCOX AND COMPANY, INC. AND ARE TO BE KEPT CONFIDENTIAL AND NOT REPRODUCED OR TRANSMITTED IN ANY FORM OR BY ANY MEANS, ELECTRONIC OR MECHANICAL, INCLUDING PHOTOCOPYING, RECORDING, OR BY ANY INFORMATION STORAGE AND RETRIEVAL SYSTEM, WITHOUT PERMISSION FROM ALLIED WILCOX PRODUCTS.

ALLIED WILCOX PRODUCTS
 2000 BRIVIA, OHIO 44130

PRODUCT SERIES
 ULTRALINE™