

DATE	REV.	DESCRIPTION	DR	CK	REL

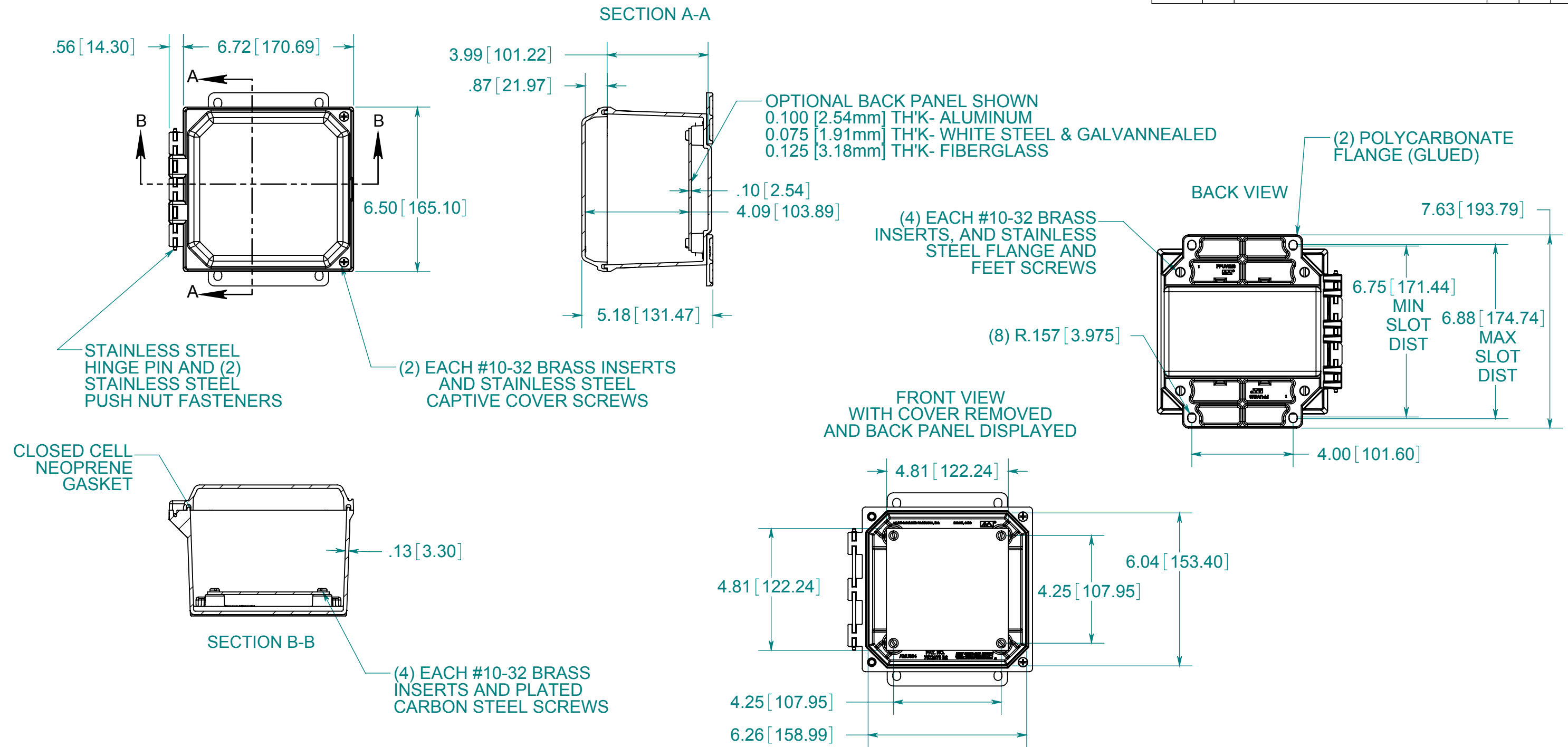
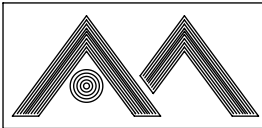

**MATERIAL:**  
 BOX- COMPRESSION MOLDED FIBERGLASS REINFORCED POLYESTER  
 COVER- COMPRESSION MOLDED FIBERGLASS REINFORCED POLYESTER  
 CLEAR COVER AND WINDOWS- POLYCARBONATE

**CONFIDENTIAL**  
 THIS MATERIAL IS OWNED BY THE ALLIED MOULDED PRODUCTS COMPANY, IS DISCLOSED IN CONFIDENCE, AND IS NOT TO BE REPRODUCED OR DISTRIBUTED WITHOUT PRIOR WRITTEN PERMISSION FROM ALLIED MOULDED PRODUCTS.

 **ALLIED MOULDED PRODUCTS**  
 BRYAN, OHIO  
 The Original Fiber Glass Outlet Box

PRODUCT SERIES

**ULTRALINE™**

Part No. **AMU664CCHF**