

DATE	REV.	DESCRIPTION	DR	CK	REL

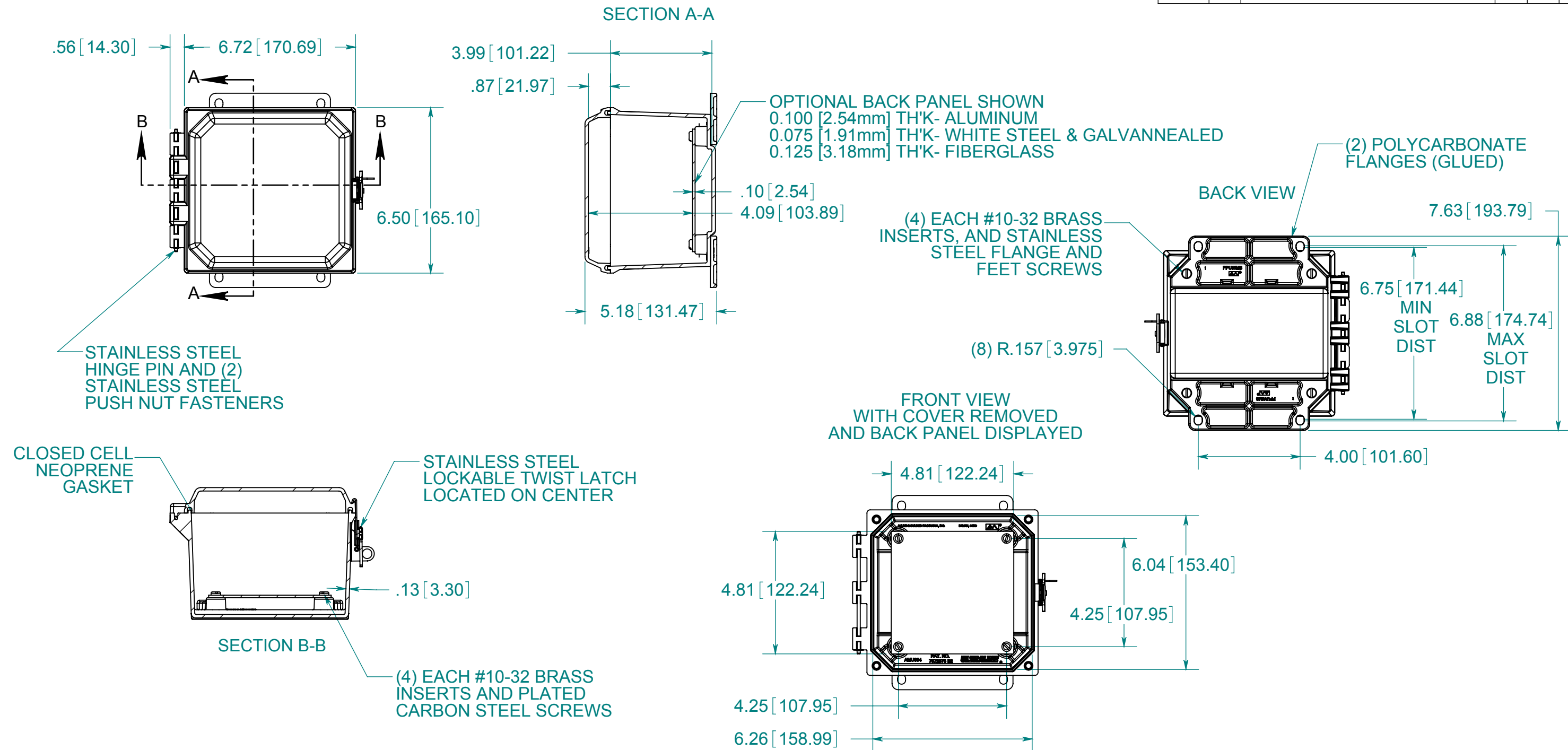
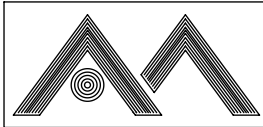

MATERIAL:
 BOX- COMPRESSION MOLDED FIBERGLASS REINFORCED POLYESTER
 COVER- COMPRESSION MOLDED FIBERGLASS REINFORCED POLYESTER
 CLEAR COVER AND WINDOWS- POLYCARBONATE

CONFIDENTIAL
 THIS MATERIAL IS OWNED BY THE ALLIED MOULDED PRODUCTS COMPANY, IS DISCLOSED IN CONFIDENCE, AND IS NOT TO BE REPRODUCED OR DISTRIBUTED WITHOUT PRIOR WRITTEN PERMISSION FROM ALLIED MOULDED PRODUCTS.

 **ALLIED MOULDED PRODUCTS**
 BRYAN, OHIO
 The Original Fiber Glass Outlet Box

PRODUCT SERIES

ULTRALINE™

Part No. **AMU664CCTF**