



**ALLIED
MOULDED
PRODUCTS, Inc.**

HMI Cover Kit

Installation Instructions for HMI Cover Kits
AMHMI108

Instructions for Installing HMI Cover Kit

NOTE: Philips Screw Driver or similar tool is required to install cover kit.

1. Punch out the template center.
2. Place template on a flat smooth surface and mark hole locations and panel opening as shown.
3. Remove template and drill or cut holes, 7/32 OR #2 (.220 DIA) and opening accordingly.
4. Mount HMI Cover with supplied mounting hardware. Hardware applicable to mounting surface thickness of .059" - .250". Hardware torque specification 15 to 20 in-lbs.
5. Hardware included:
 - P/N 70-10321: 10-32 X 1 Pan Head Machine Screw, quantity 10.
 - P/N 70-EMRWASHER: Stainless Steel Washer Rivet, quantity 10.
 - P/N 55-1032: Nut 10-32 With Nylon Insert, quantity 10.

Note: Part includes padlock feature on latch that may be used to prevent unauthorized or unintentional opening of the latches.

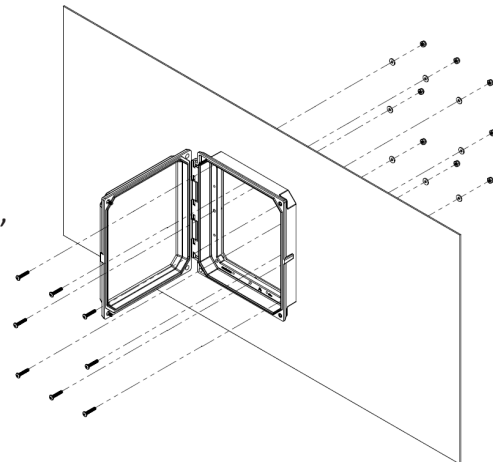
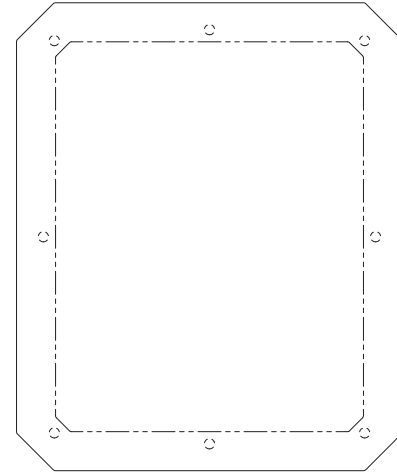

Allied Moulded Products, Inc.
222 North Union Street • Bryan, OH 43506
Phone: 1-800-722-2679 • Fax: 1-800-237-7269
www.alliedmoulded.com