

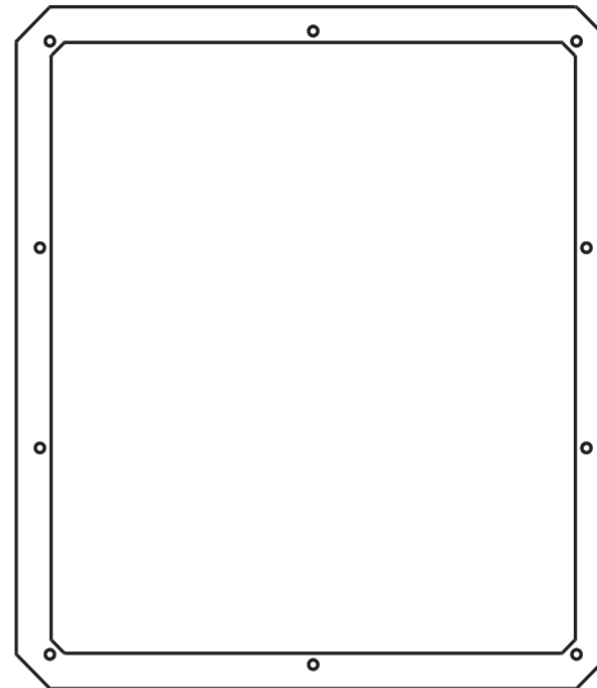

Instructions for Installing HMI Cover Kit

NOTE: Philips Screw Driver or similar tool is required to install cover.

1. Punch out the template center.
2. Place template on flat smooth surface and mark hole locations and panel opening as shown.
3. Remove template and drill or cut holes, 7/32 OR #2 (.220 DIA) and opening accordingly.
4. Mount HMI Cover with supplied mounting hardware. Hardware applicable to mounting surface thickness of .059" - .250". Hardware torque specification 15 to 20 in-lbs.
5. Hardware included:
 - P/N 70-10321: 10-32 X 1 Pan Head Machine Screw, quantity 10.
 - P/N 70-EMRWASHER: Stainless Steel Washer Rivet, quantity 10.
 - P/N 55-1032: Nut 10-32 With Nylon Insert, quantity 10.



Note: Part includes padlock feature on latch that may be used to prevent unauthorized or unintentional opening of the latches.

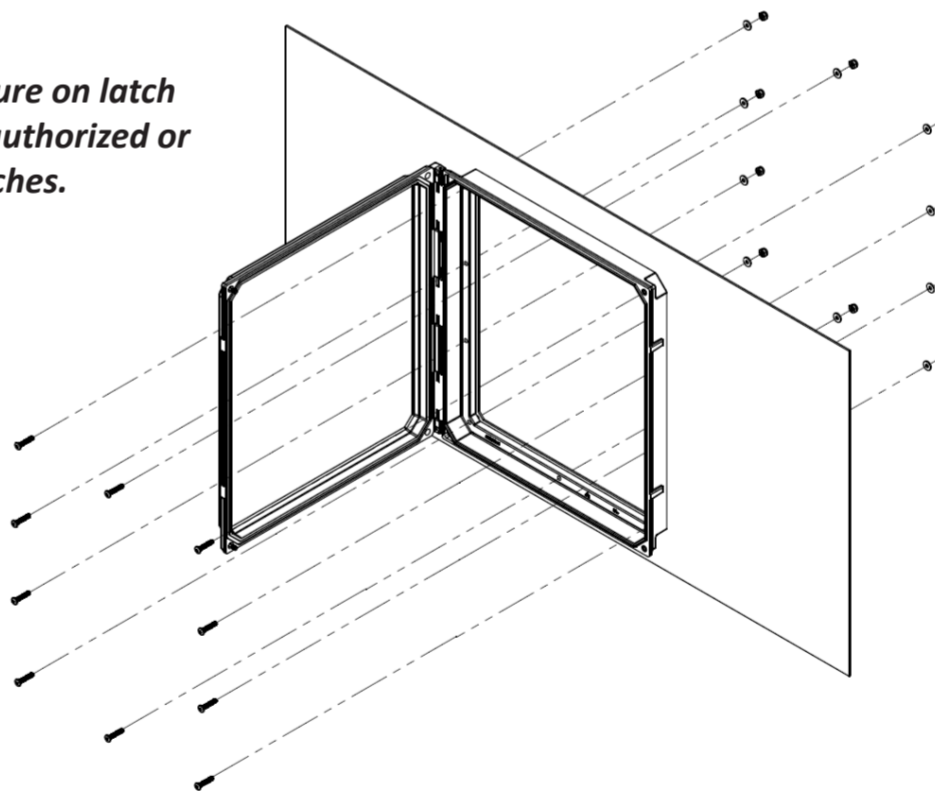

Allied Moulded Products, Inc.
222 North Union Street • Bryan, OH 43506
Phone: 1-800-722-2679 • Fax: 1-800-237-7269
www.alliedmoulded.com