



**ALLIED
MOULDED
PRODUCTS, Inc.**

Inspection Window Installation
Installation Instructions for Inspection Window
AMHMI95CX

Instructions for Installing Inspection Window

NOTE: Philips Screw Driver or similar tool is required to install cover.

1. Punch out the template center.
2. Place template on a flat smooth surface and mark hole locations and panel opening as shown.
3. Remove template and drill or cut holes 5/16" (0.312 DIA) and opening accordingly.
4. Mount Inspection Window with supplied mounting hardware. Hardware applicable to mounting surface thickness of .059" - .250". Hardware torque specification 12 – 15 in-lbs.
5. Hardware included:
 - 70-10325, 10-32 X 1/2" Pan Head Machine Screw; Quantity 10
 - 70-EMRWASHER, Stainless Steel Washer; Quantity 10

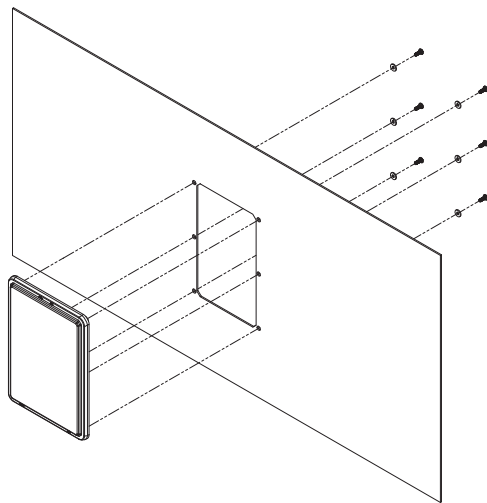

Allied Moulded Products, Inc.
222 North Union Street • Bryan, OH 43506
Phone: 1-800-722-2679 • Fax: 1-800-237-7269
www.alliedmoulded.com