

Date	Rev	Description	ECN No.	ISSUE DATE	DB	CK	REL
08/02/2019		INITIAL RELEASE	ECN-314		DJL	SRH	GEL
-	-	-	-	-	-	-	-
-	-	-	-	-	-	-	-

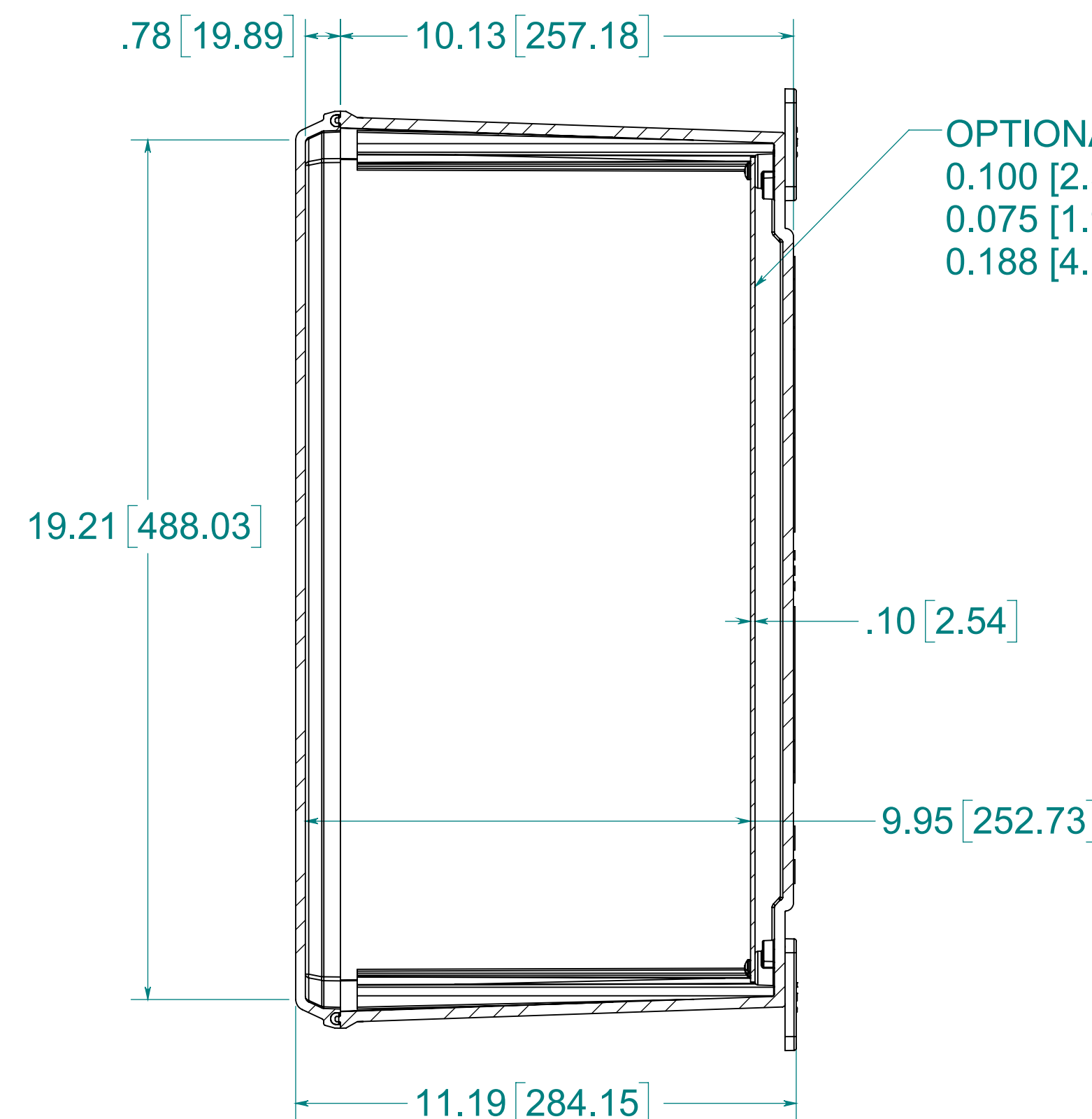

SECTION A-A

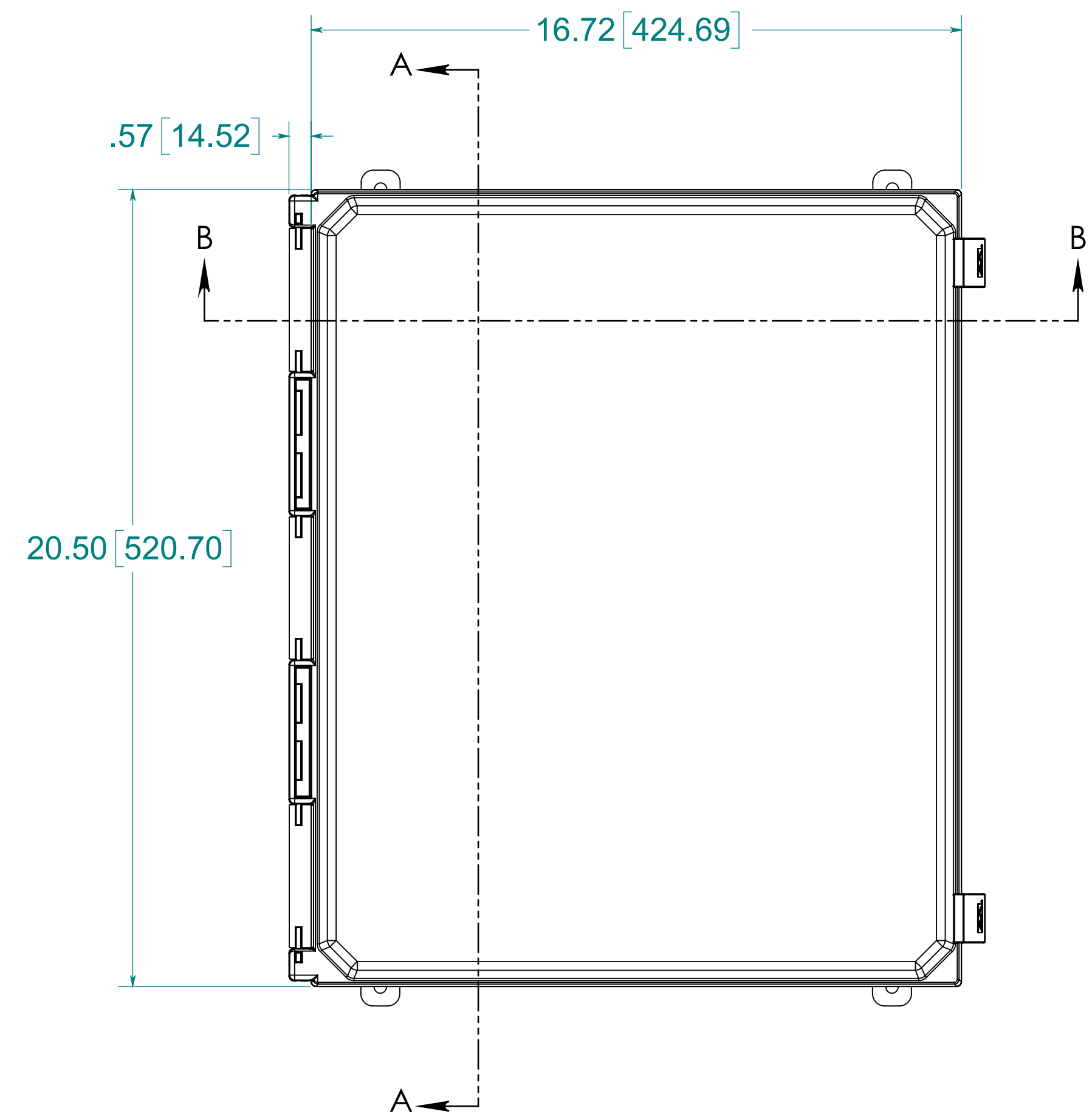
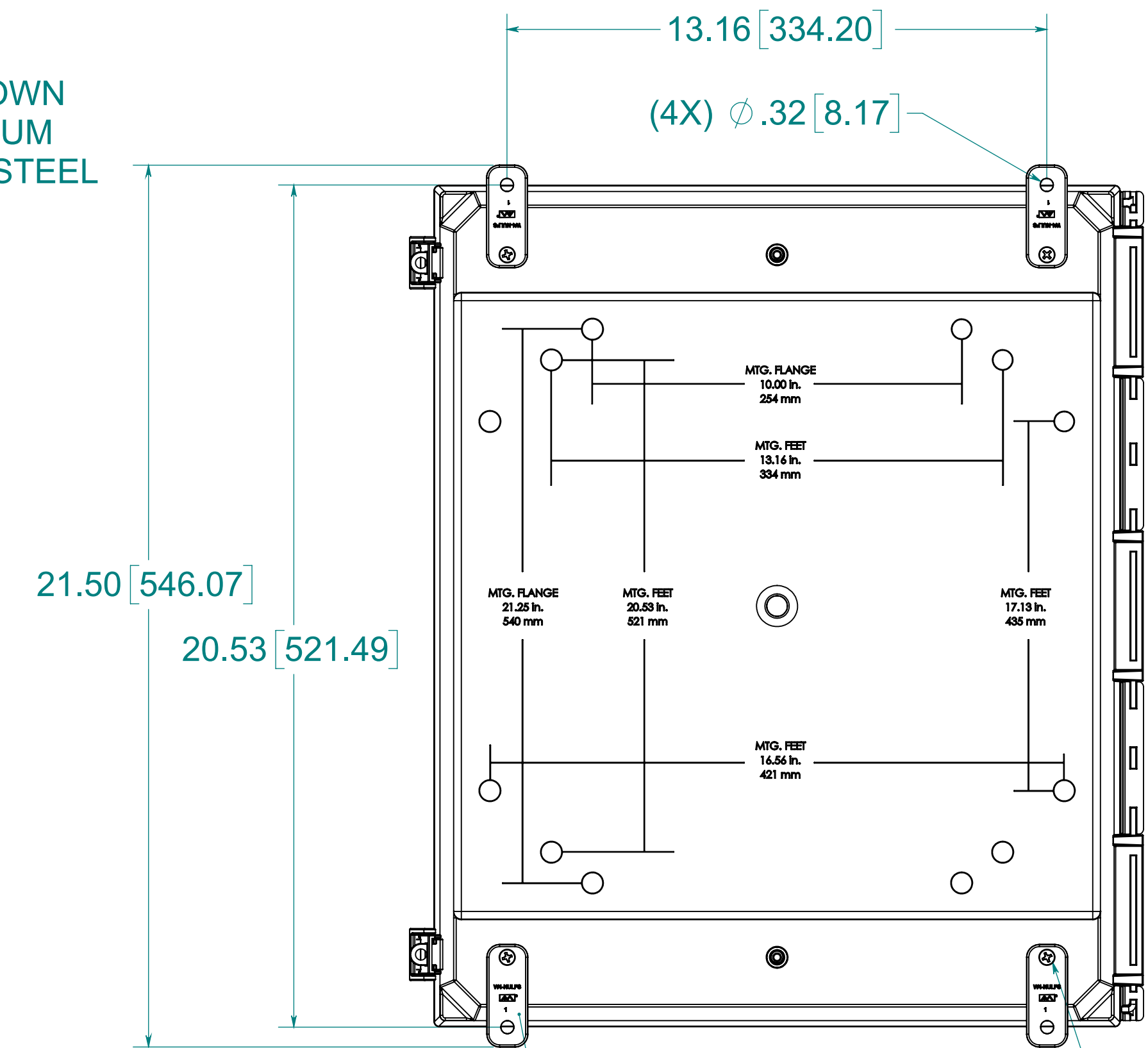

(4X) POLYCARBONATE FEET  
(4X) EACH #10-32 BRASS INSERTS AND 316 STAINLESS STEEL FLANGE SCREWS

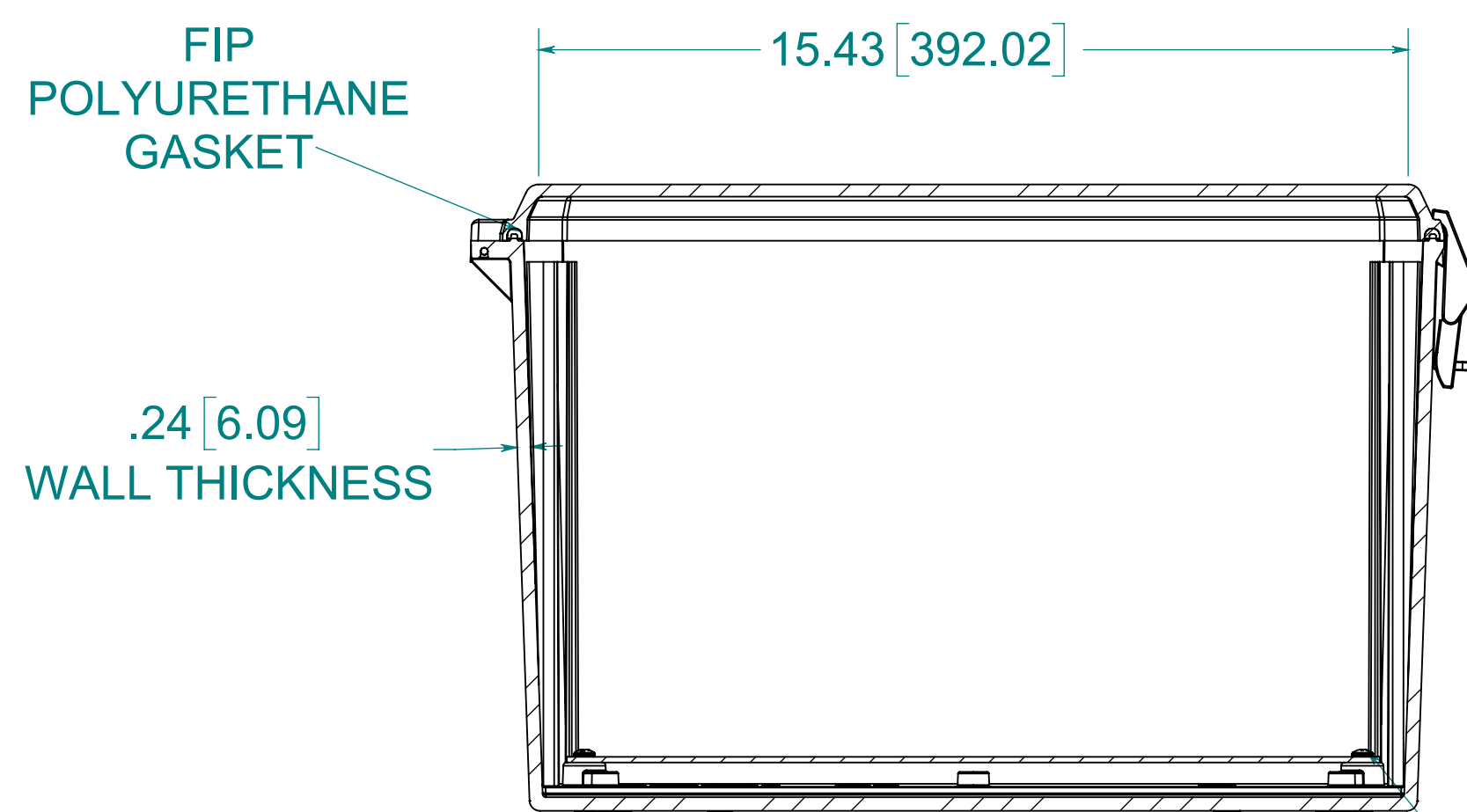

SECTION B-B

(2X) NON-METALLIC LOCKABLE SNAP LATCH  
(4X) EACH #10-32 BRASS INSERTS AND PLATED CARBON STEEL SCREWS

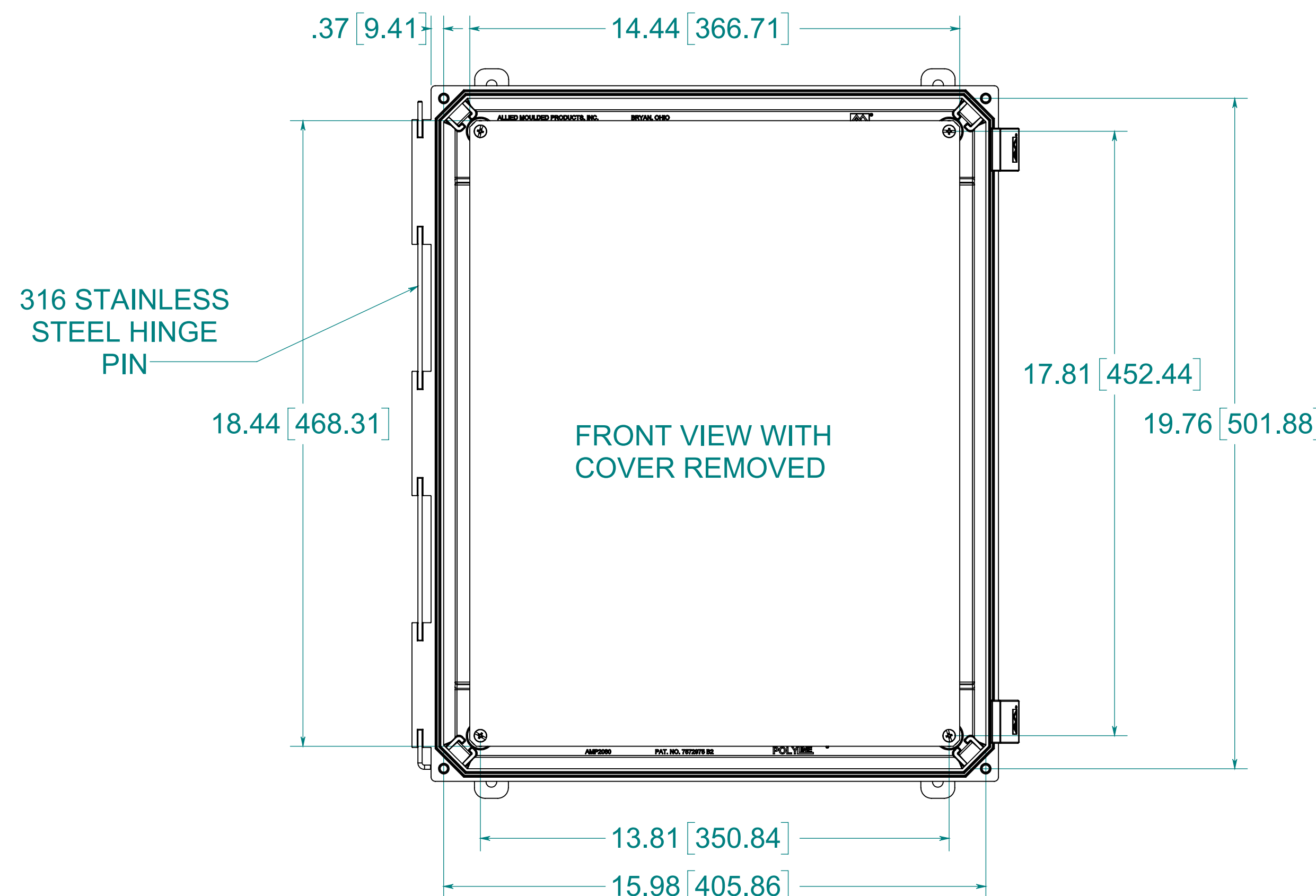

FRONT VIEW WITH COVER REMOVED

**MATERIAL:**  
BOX- INJECTED POLYCARBONATE  
STANDARD COVER- INJECTED POLYCARBONATE  
CLEAR COVER- INJECTED POLYCARBONATE

NOTE;  
1. DATA SUBJECT TO CHANGE WITHOUT NOTICE



**CONFIDENTIAL**  
THIS MATERIAL IS OWNED BY THE ALLIED MOULDED PRODUCTS COMPANY, IS DISCLOSED IN CONFIDENCE, AND IS NOT TO BE REPRODUCED OR DISTRIBUTED WITHOUT PRIOR WRITTEN PERMISSION FROM ALLIED MOULDED PRODUCTS.  
© 2018 Allied Moulded Products, Inc.  
All Rights Reserved

Description  
**AMP Polyline**  
Part No.  
**AMP2060CCNI**