

# **ULTRALINE<sup>®</sup>**

From Allied Moulded Products 

## **Aluminum Hinged Front Panel**

### **Installation Instructions**

# **HFPU164**



**ALLIED  
MOULDED  
PRODUCTS, Inc.**

222 N. Union St. Bryan, OH 43506  
PH: 419-636-4217 • FAX: 800-237-7269

[www.alliedmoulded.com](http://www.alliedmoulded.com)

INST-HFPU164

# HFPU164 ASSEMBLY

1

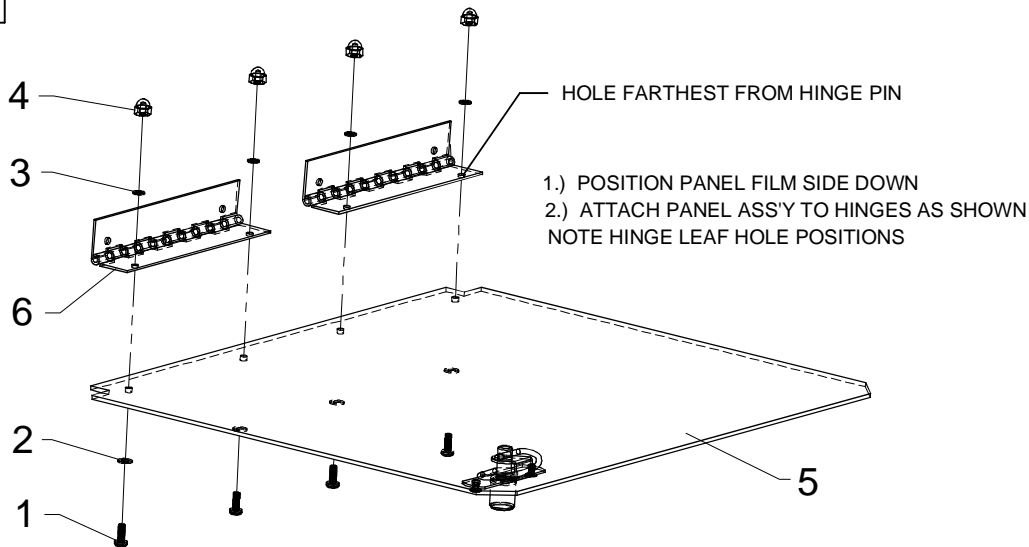

## HFPU164

- 1) #6-32 x 3/8 SCREW (4)
- 2) #6 FLAT WASHER (12)
- 3) #6 LOCK WASHER (8)
- 4) #6-32 ACORN NUT (8)
- 5) U60832 PANEL/LATCH ASS'Y (1)
- 6) 70-60804 5" HINGE (2)
- 7) 70-UPANST164 PANEL STOP (1)
- 8) 70-UPANST164EX EXTEND PANEL STOP (1)
- 9) #10-32 x 5/16 SCREW (2)
- 10) #10-32 x 7/16 SCREW (2)
- 11) #6-32 x 3/4 SCREW (4)
- 12) 70-UDGS164 DRILL GUIDE (2)
- 13) 70-60431NYLON (4)

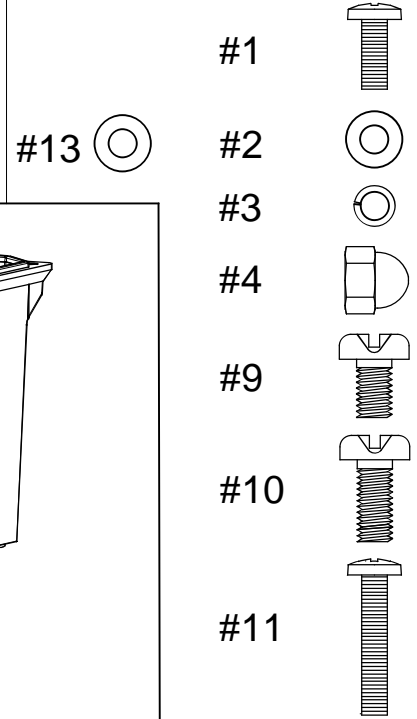

2

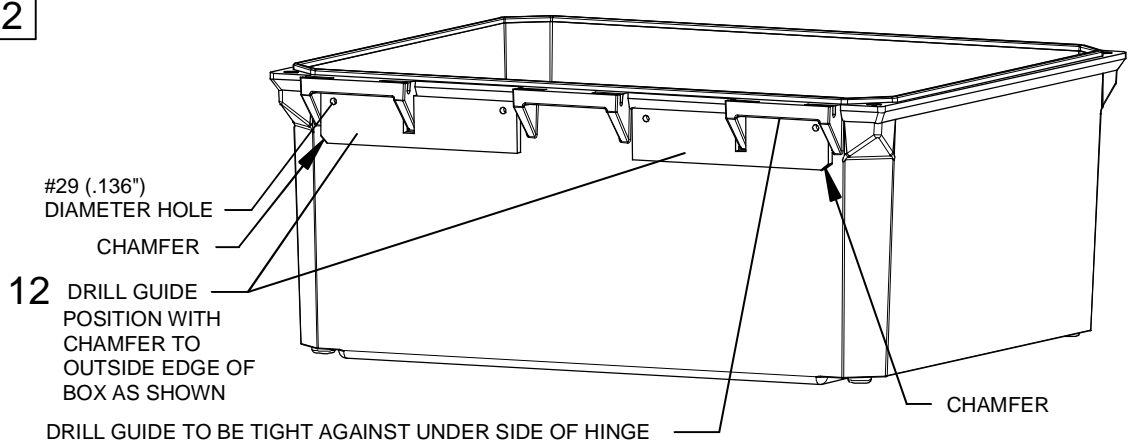

- 1) POSITION DRILL GUIDE PLATES AS SHOWN, **DRILL GUIDES TO BE USED AS SPACER IN STEP #3**
- 2) DRILL FOUR #29 (.136") DIAMETER HOLES

3

- 1) PLACE WASHER #13 ONTO SCREW #11 AND INSERT #11 & #13 THROUGH WALL OF BOX. PLACE DRILL GUIDE #12 (USED AS SPACER) BETWEEN THE BOX INSIDE WALL AND HINGE #6
- 2) ASSEMBLE PANEL STOPS #7 & #8 WITH TWO SCREWS #9 OR #10 WITH ENCLOSURE BACK PANEL. PANEL STOPS SHOULD LAY AGAINST THE BOX WALL

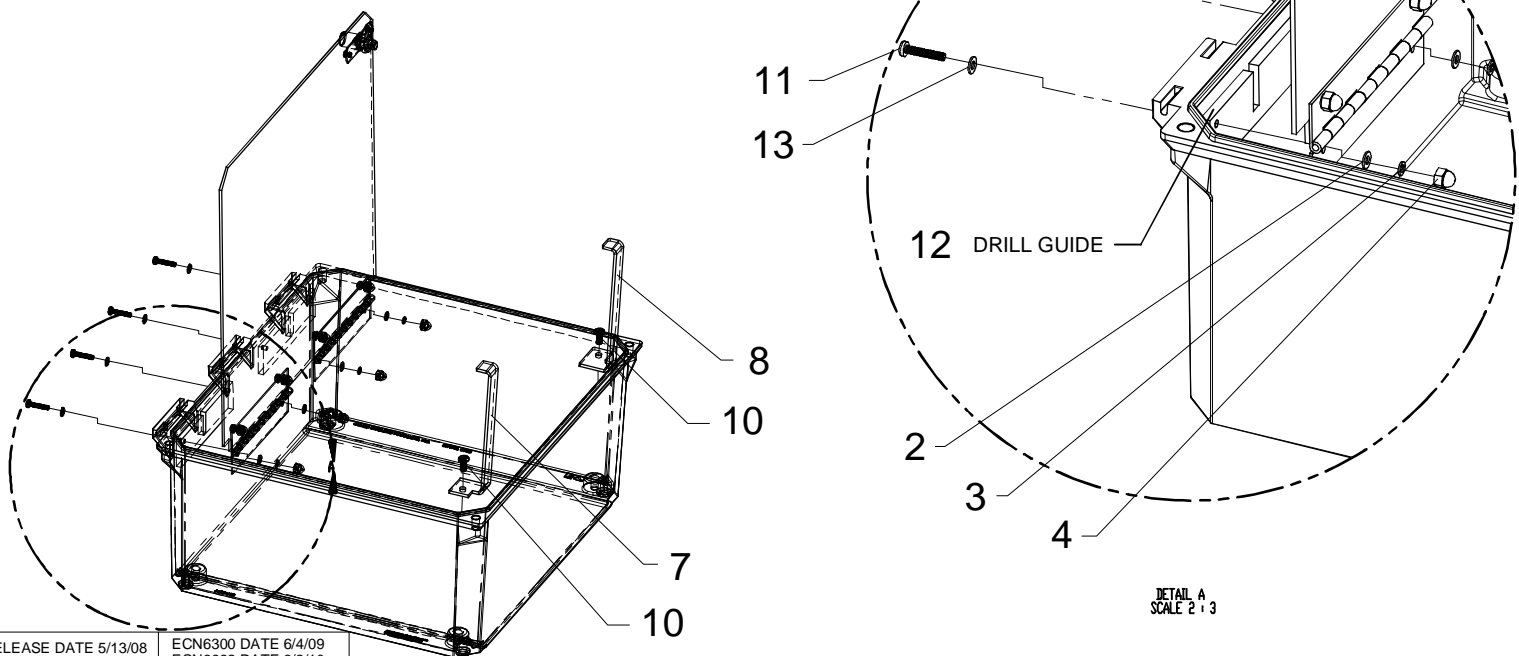

DETAIL A  
SCALE 2:3